

COMPONENTS AND INSTALLATION HANDBOOK

LANDIRENZO OMEGAS/GI



**LPG
5-6-8 CYLINDERS**



LANDIRENZO®

Table of Contents

CHAPTER 1	SYSTEM DESCRIPTION	5
1.1	Principle of operation	5
CHAPTER 2	SIGNALS PROCESSED	7
2.1	INPUT signals	7
2.1.1	Petrol injection signals	7
2.1.2	RPM (Engine Revolution) signal	7
2.1.3	MAP pressure signal (if present)	7
2.1.4	Engine coolant temperature signal (optional)	7
2.1.5	Gas temperature signal	7
2.1.6	Gas pressure signal	7
2.1.7	Gas level sensor	7
2.2	OUTPUT signals	8
2.2.1	Gas injection signals	8
2.2.2	Driving the gas solenoid valves	8
2.2.3	Petrol/gas switch/Indicator	8
2.2.4	PC diagnostics	8
CHAPTER 3	COMPONENTS	9
3.1	IG1 PRV vaporizer/pressure regulator	11
3.2	Water temperature sensor (optional)	12
3.3	Filter FL-ONE	13
3.4	Injector rail	14
3.5	Nozzle – manifold	16
3.5.1	Standard nozzle	16
3.5.2	Optional nozzle	16
3.6	LANDIRENZO OMEGAS control unit	16
3.7	Petrol/gas switch	19
3.8	Wiring harness	20
3.8.1	Injection system	20
3.8.2	Injector cutting harness	22

CHAPTER 4	INSTALLATION	23
4.1	Equipment/tools required	23
4.2	Assorted workshop materials	23
4.3	Before starting the installation	23
4.4	Assembling components	24
4.4.1	Notes relating to all components involved in handling gas	24
4.4.2	Closing and opening the CLIC-R clamps on the gas tubes	24
4.4.3	Vaporizer/pressure regulator	25
4.5	Filter unit	26
4.6	Injector rail	27
4.7	Nozzles	28
4.8	Connection tubes	29
4.8.1	Engine system	29
4.9	ECU	32
4.10	Petrol/gas switch	32
4.11	Electrical connections	33
4.11.1	System for aspirated engine with IG1 regulator	33
4.11.2	System for aspirated engine with two IG1 regulators	34
4.12	Recommendations	35
4.13	Tank	35
4.14	In case of accident	35
CHAPTER 5	REMINDER	36
5.1	Installation	37
5.2	Engine idling	38
5.3	Slight acceleration from idle	39
5.4	High acceleration from idle	39

5.5	Petrol-gas changeover	40
5.6	Returning to idle	41
5.7	Full open throttle engine operation	42
5.8	Full throttle acceleration at medium-high regimes	43
5.9	High torque low RPM operation	43
5.10	Miscellaneous	44
5.11	Diagnosis	45
5.12	LR OMEGAS program error codes	48
CHAPTER 6	GLOSSARY	49



Do not under any circumstances tamper with the original Landi Renzo components, especially with the engine running or with the control panel inserted.



Washing the engine with water jet and installation in unsuitable parts of the engine compartment may lead to water penetration into the components (control unit, reduction unit, injectors, etc.) leading to damage.

LANDIRENZO S.p.A declines any responsibility for damage or injury to persons or objects caused by tampering with components by unauthorised personnel.

CHAPTER 1

SYSTEM DESCRIPTION

1.1 PRINCIPLE OF OPERATION

The LANDIRENZO OMEGAS phased sequential system is part of the latest generation of petrol to gas phase LPG conversion systems on the market. The principle with which the gas ECU determines the injection times actuated on the gas injectors is based on the acquisition, during the gas operation of the petrol injection times on emulation impedances internal to the gas ECU itself. This means that the control of the motor is left to the petrol control unit while the gas control unit is given the task of converting the data generated by the former for the petrol injectors, into suitable data for the gas injectors.

To put it in simple terms, one could say that the gas control unit converts a certain quantity of energy that should have been released from petrol into a corresponding quantity of energy that will be really released by the gas.

The result is that the system is as uninvasive as possible compared with the original petrol system and is able to integrate effectively with the latter's main (controlling fuel ratio, cut off, EGR, purge canister, cut off for over-revving, etc.) and secondary (air-conditioner clutch control, power steering overpressure, electrical loads, etc.) functions.

The conversion of petrol injection times in gas injection times is carried out on the basis of a series of parameters, in addition to the petrol injection times acquired by the gas ECU:

- gas pressure in the rail
- gas temperature
- engine water temperature
- engine revolutions
- battery voltage.

In particular, aiming at maintaining perfect coherence with the petrol system, the gas ECU actuates the injection of the gas on the same cylinder on which the petrol injection time was acquired.

Start-up normally occurs with petrol and, in emergency conditions, there is an option for starting with gas by means of a Petrol/gas switch. Having started the engine, if the Petrol/gas switch is in the gas position, the gas ECU (*Electronic Control Unit*) checks for the conditions that must be verified for switching.

The liquid gas, which is stored in the tank at a pressure that depends on its composition and the ambient temperature, is atomized in the reducer and adjusted to an output pressure that is 1 bar higher than the pressure in the suction manifolds.

From the moment at which the following conditions are reached: minimum RPM threshold, minimum engine coolant temperature and acceleration or deceleration, the solenoid valves open and after 1 second the system switches to gas.

At this point, the petrol injectors are deactivated and the gas ECU starts to drive the gas injectors.

The gas ECU reads each individual petrol injection time and translates it into a gas injection time to drive the relative injector set in correspondence to the same cylinder.

For this reason, the injector supplies the correct quantity of gas that reaches the suction manifold.

The precise calibration of the map obtained using Landi Renzo software means that there is no need for specific adaptability to gas, but that everything can be assigned to petrol adaptability.

In addition to managing the gas injectors, the LANDIRENZO OMEGAS ECU also controls other functions for the purpose of completing the system, such as the level of fuel, the operation of the solenoid valves, the transfer back to petrol when the LPG runs out, etc.

During the assembly and maintenance phases, it is possible to display the operation of the system and check the diagnostics by connecting a PC to the LANDIRENZO OMEGAS ECU, by using the Omegas interface software and a serial RS 232 or USB interface.

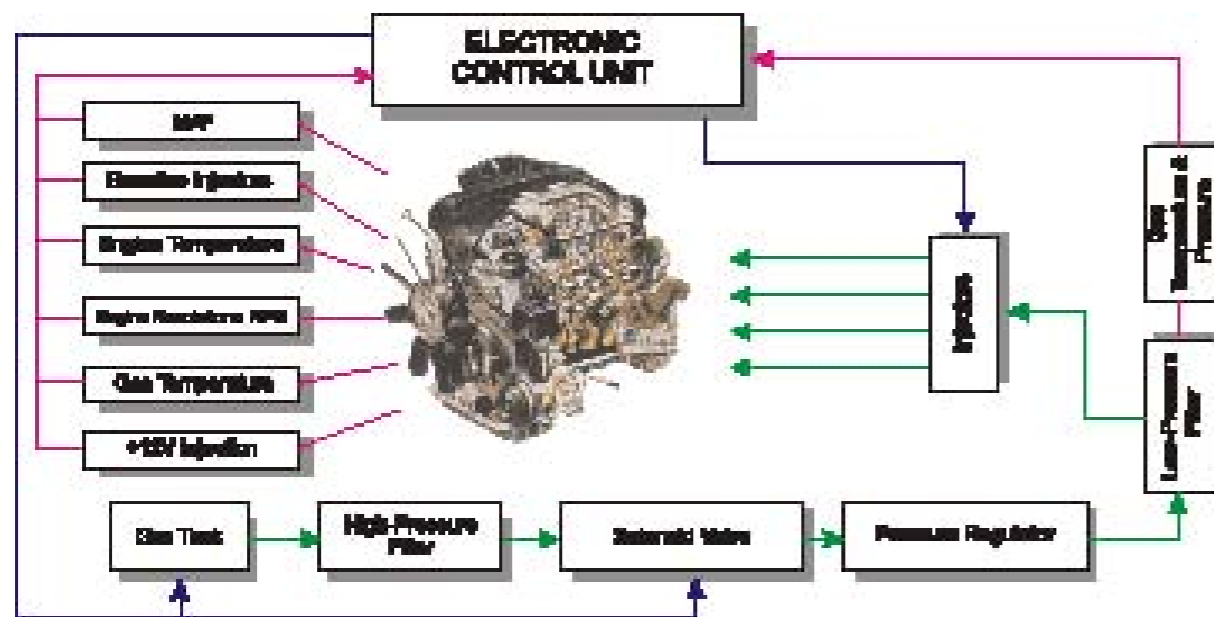

Fig. 1

CHAPTER 2 SIGNALS PROCESSED

2.1 INPUT SIGNALS

2.1.1 Petrol Injection signals

The system uses petrol injection times as the main parameters for the calculation of the quantity of LPG to inject: the gas ECU converts the petrol injection times into gas injection times and actuates them by means of the gas injectors. Nevertheless, the voltage provided to the petrol injectors is also used for recognizing the root key.

2.1.2 RPM (Engine Revolution) Signal

The RPM signal is one of the two basic parameters, together with the petrol injection time, used for converting the petrol injection time into a gas injection time.

It is also used for checking if the engine is running or stopped. For this signal, it is necessary to connect a cable to the engine's ignition system.

2.1.3 MAP pressure signal (if present)

The MAP signal is used to manage the switch back to petrol if the LPG should run out. It should be connected to the wire of the original vehicle sensor (ref. B figs 25 and 26).

2.1.4 Engine coolant temperature signal (optional)

The coolant temperature is used:

- to manage the petrol – gas transfer;
- to correct the gas injection time.

This correction is used to manage engine warm-up during gas operation.

The software includes a new strategy to ensure that if the wire is not connected the switch from petrol to gas is still managed correctly.

2.1.5 Gas Temperature Signal

The temperature of the gas is used to correct the gas injection time; this correction tends to compensate for the variations in density and volumetric energy during engine operation upon the variation of the same temperature.

If the water temperature reading wire is not connected this is used to manage the switch from petrol to gas.

2.1.6 Gas Pressure Signal

As the pressure of the gas increases, its density and volumetric energy increase. To compensate for this, a pressure correction of the gas injection time is used.

The gas pressure signal is also used to determine when to actuate the transfer back to petrol in the event that the LPG tank is empty or the gas filter is clogged.

2.1.7 Gas Level Sensor

The fuel level sensor on the multivalve tells the ECU how much LPG remains in the tank. The ECU uses this signal to make it visible to the user, using the fuel level indicator integrated into the Petrol/gas switch unit together with the fuel switch. It is also used to tell the user if problems have occurred and if diagnostics are set or the transfer back to petrol has been implemented.

2.2 OUTPUT SIGNALS

2.2.1 Gas Injection Signals

The ECU uses gas injection times, calculated beginning from the petrol injection times, to drive the gas injectors and allow the correct operation of the vehicle.

2.2.2 Driving the Gas Solenoid Valves

The gas control unit drives the system's two solenoid valves in the:

- tank
- reducer/atomizer.

2.2.3 Petrol/gas switch/Indicator

The Petrol/gas switch/indicator shows:

- the type of fuel in use;
- the quantity of LPG in the tank;
- diagnostic and acoustic signals.

2.2.4 PC Diagnostics

The Personal Computer is used for:

- programming the gas ECU;
- vehicle diagnostics.

CHAPTER 3 COMPONENTS

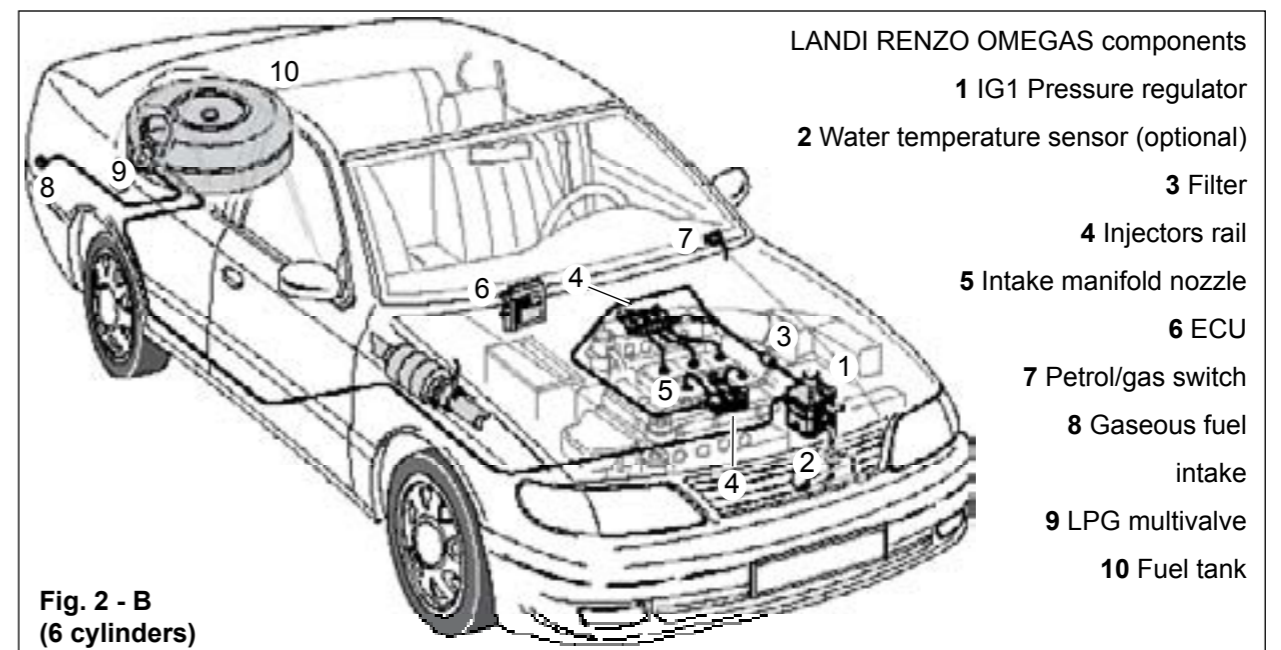
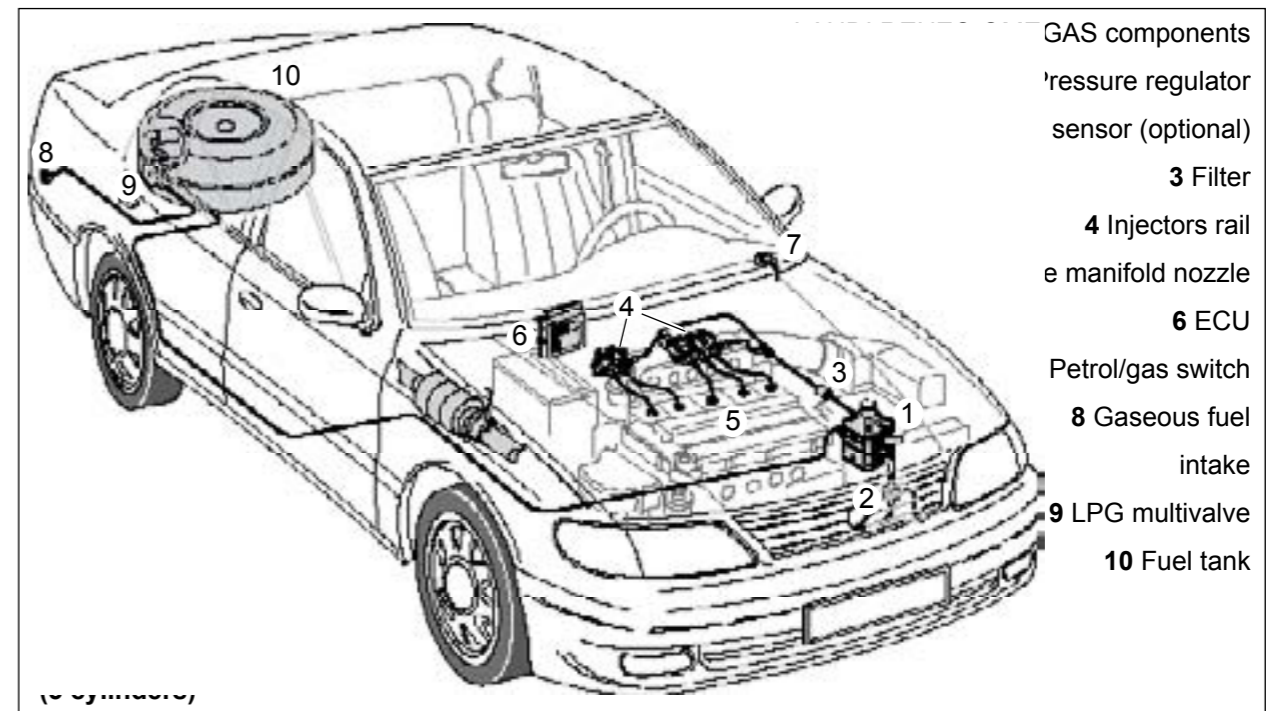

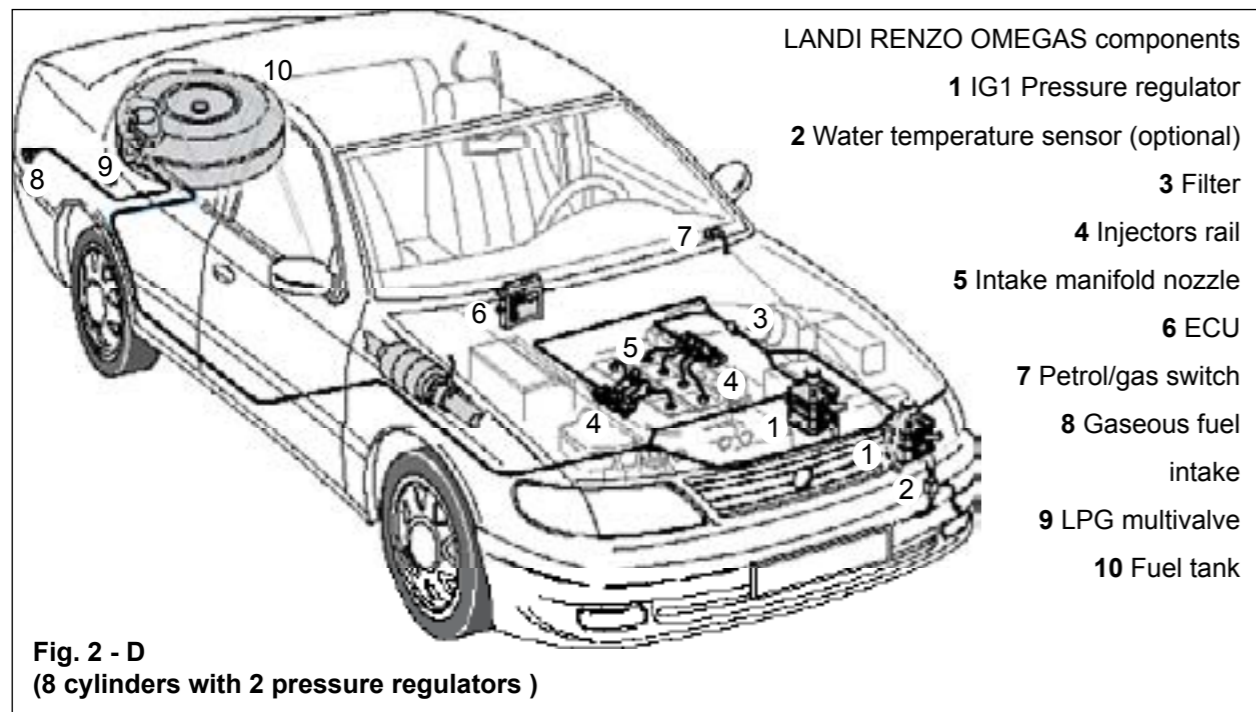
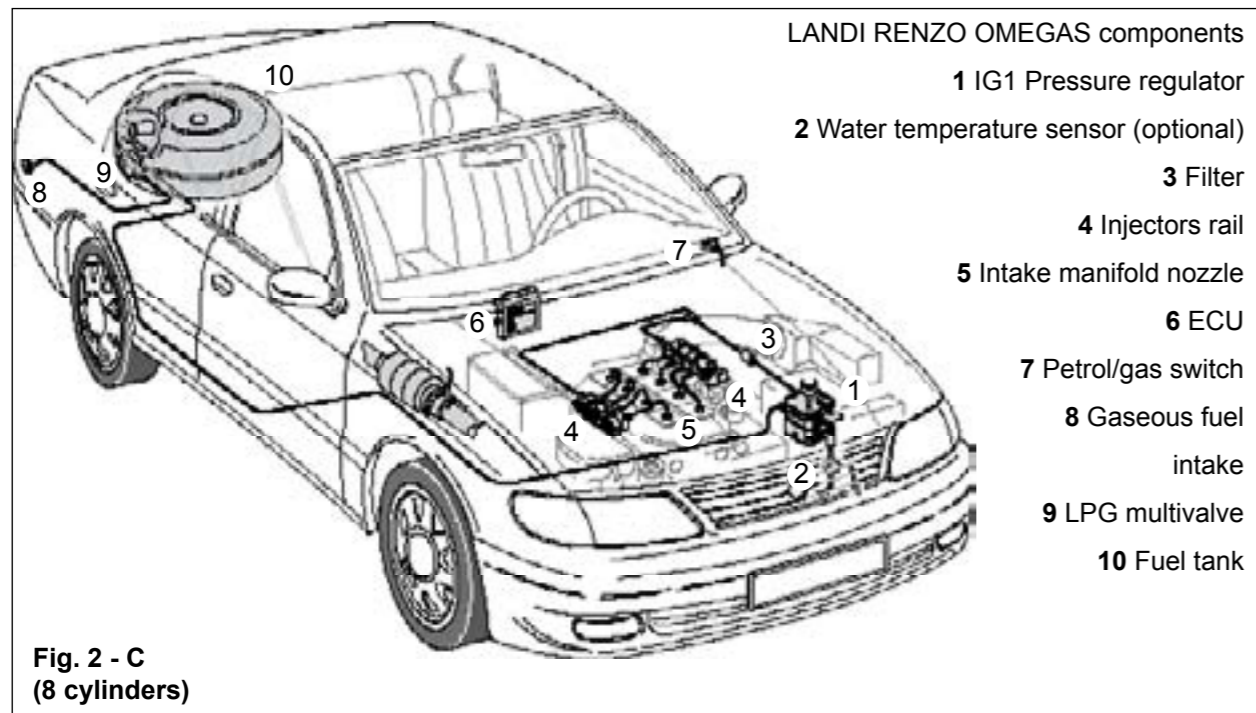

3.1 IG1 PRV VAPORIZER/PRESSURE REGULATOR (Oversize version for aspirated engine, turbo version for turbocharged engine)

The pressure regulator (Fig. 3) is a two-stage, compensated, diaphragm type, with water-gas heat exchanger, gas solenoid valve with incorporated filter and internal safety valve. It is calibrated for a supply pressure of 0.95 bar (95 kPa) in the aspirated engine, 1.1 bar (110 kPa) in the turbocharged engine, higher than the pressure present in the suction conduits for normally-aspirated and turbo vehicles.

Technical specifications:

Weight	1870 g.
Nominal operating flow rate	50 Kg/h
Working temperature	-20 to 120 °C
Safety valve calibration pressure	3.5 bar (350 kPa)
Working pressure	0.95 bar (95 kPa)
EV coil electrical characteristics	12V 11W
Type approval	R67
	E 13 67R-010025

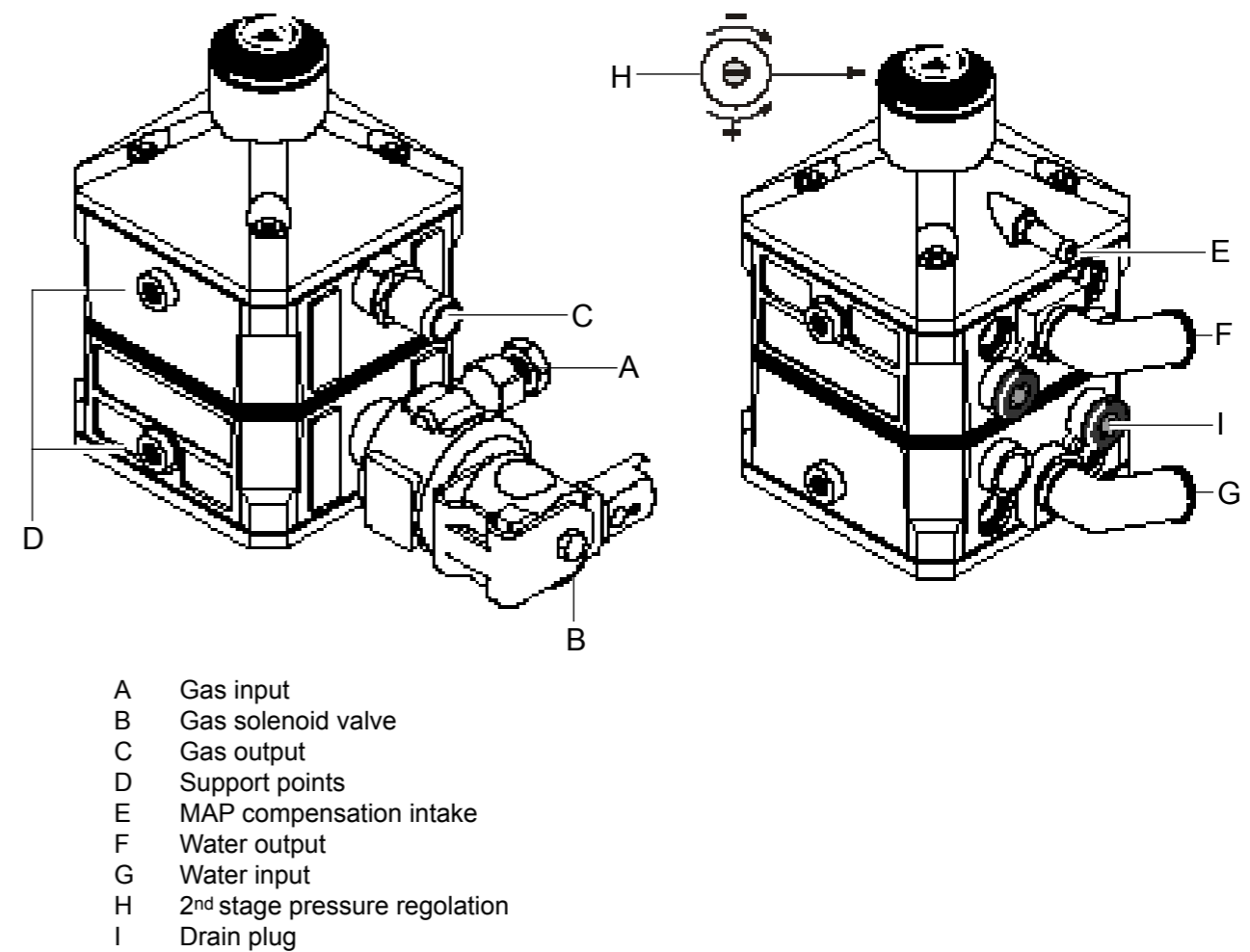

Fig. 3

3.2 WATER TEMPERATURE SENSOR (OPTIONAL)

When setting up the system there are three 3 different options to choose from (ref A. figs. 25 and 26).

- A1 Use of currently optional water T sensor, purchase separately.
- A2 Connection of orange wire (PIN N° 33) to the original vehicle water temperature sensor
- A3 Neither of the 2 wires connected.

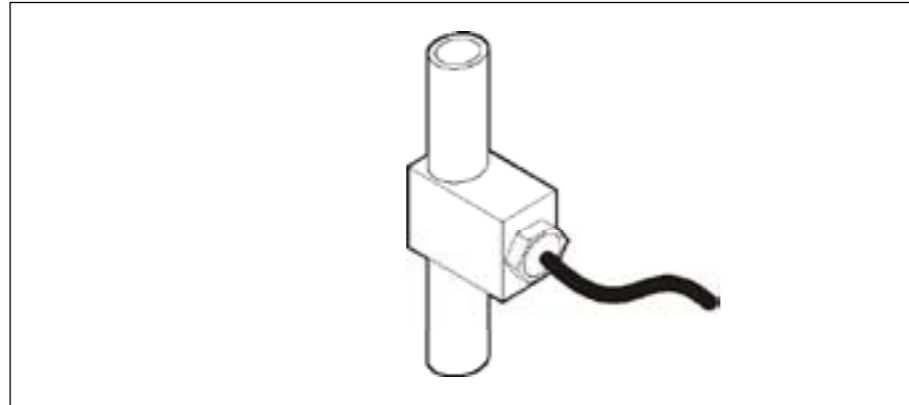

Fig. 4

In all three cases the switch from petrol to gas is managed correctly. The temperature sensor is fitted on the cooling circuit just upstream of the pressure regulator. The electric signal is sent to the ECU as part of a string of information necessary for the engine running on gas.

Technical specifications:

Weight	71 g.
Tube connection	15 mm
Sensor type	4.7 ohm
Connector:	IP 54 type SICMA 2

3.3 FILTER FL-ONE

The filter has the function of filtering the LPG in the gas phase.

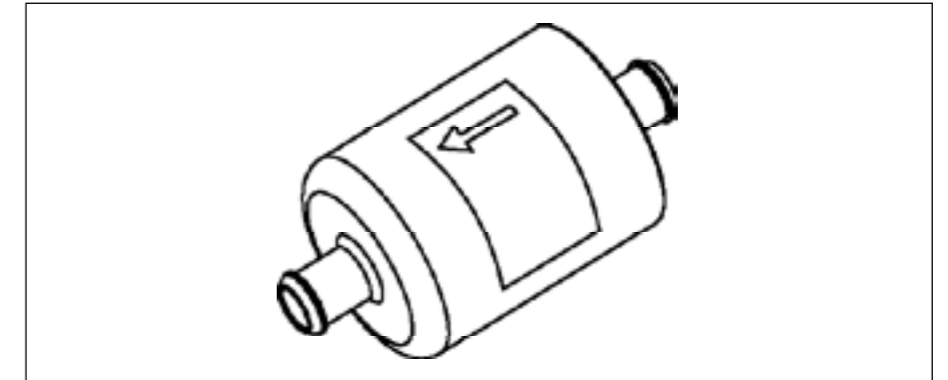

Fig. 5

The input of the filter is connected to the output of the pressure reducer using a tube with an internal diameter of 14 mm. The filter contains a replaceable filtering cartridge which has the function of obtaining effective filtering in the direction of the gas flow from the outside towards the inside. The output of the filter is connected to the input of the injector rail using a tube

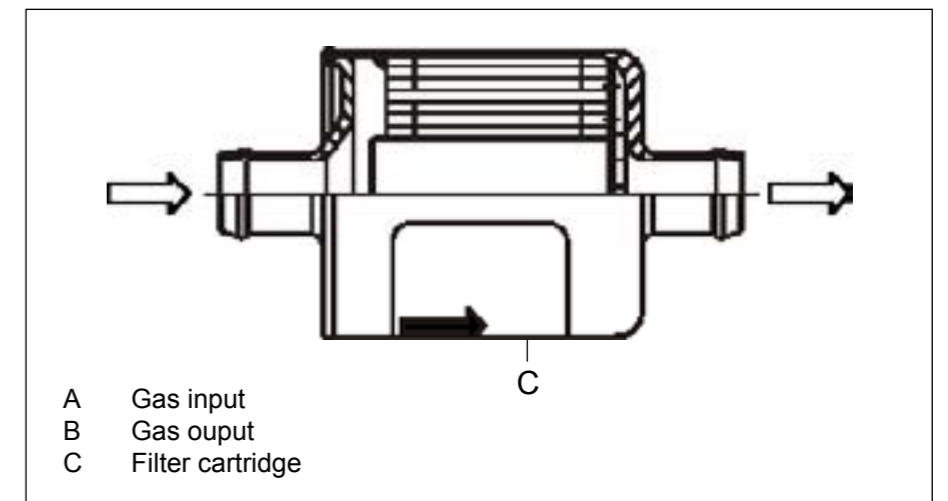

Fig. 6

with an internal diameter of 14 mm.

Technical specifications:

Weight	82 g.
Degree of filtration	80µmm
Maximum working pressure	4 bar
LPG type approval N°:	E13 67R-010181
Input / output gas pipe	Ø14 mm

3.4 INJECTOR RAIL

The LPG, coming from the filter, enters fitting A and feeds the injectors. Appropriately dosed, the gas exits the injectors through nozzles B and reaches, through a suitable connector, the suction manifold and, thus, the engine. The injectors are driven by the gas ECU and are connected to it through the connectors D. The gas pressure and temperature are measured by sensor C.

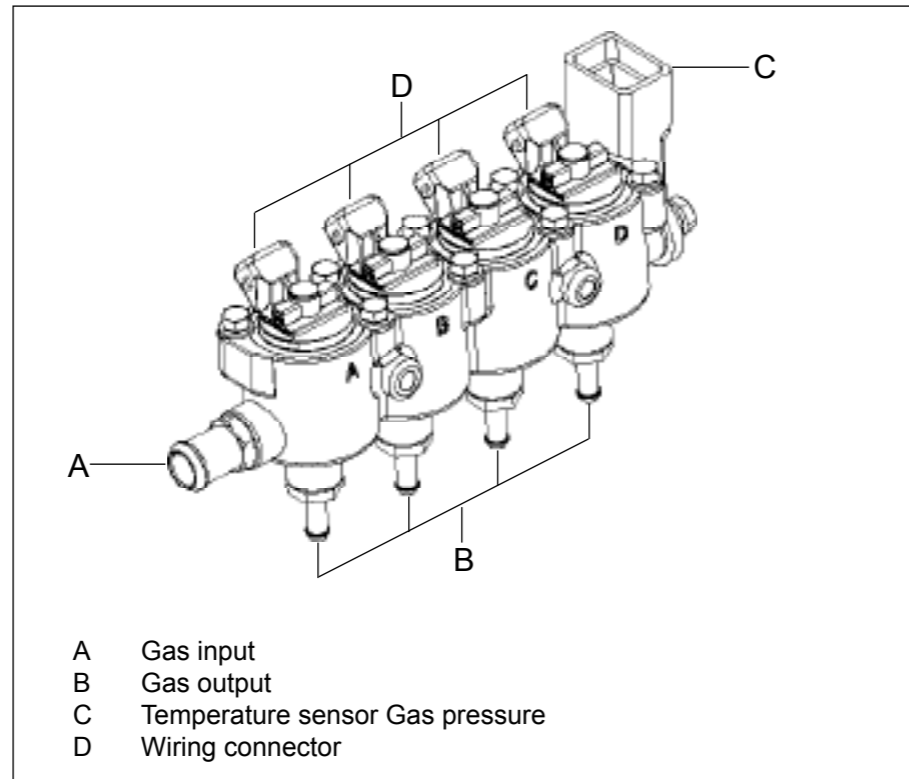

Fig. 7

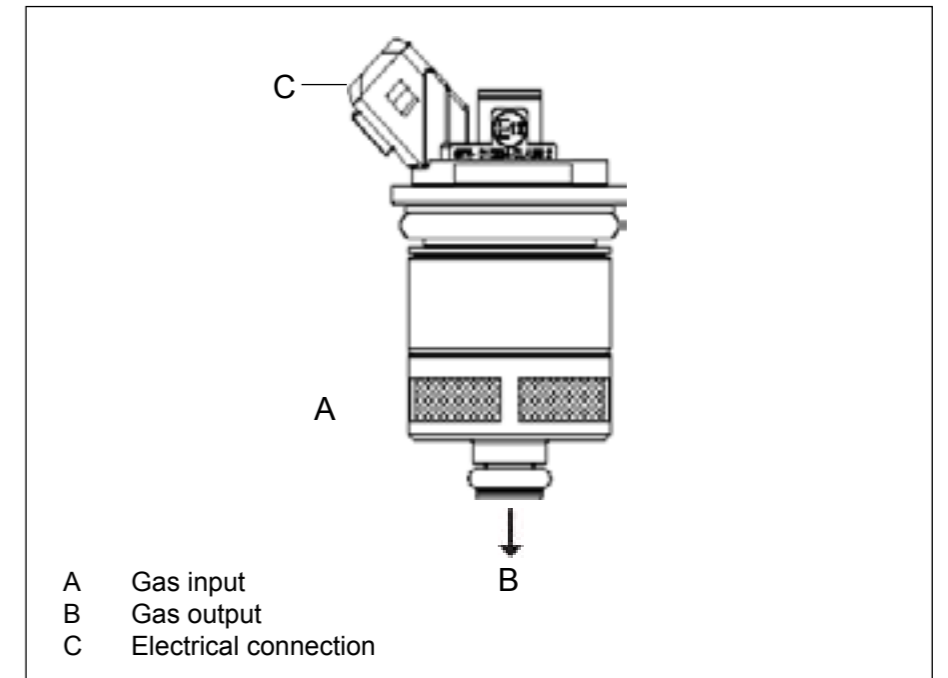

Fig. 8

Technical specifications:

Weight (4-cylinders)	~ 850 g.
Injectors per rail:	3 or 4
Response time:	1.7 ms ± 0.2
Working temperature:	-40 to + 120° C (R110)
Maximum working pressure:	3 bar
Power absorbed:	1 W in maintenance
LPG injector type approval N°:	E13 67R-010234
LPG injector rail type approval N°:	E13 67R-010233
Driving method:	Peak and Hold

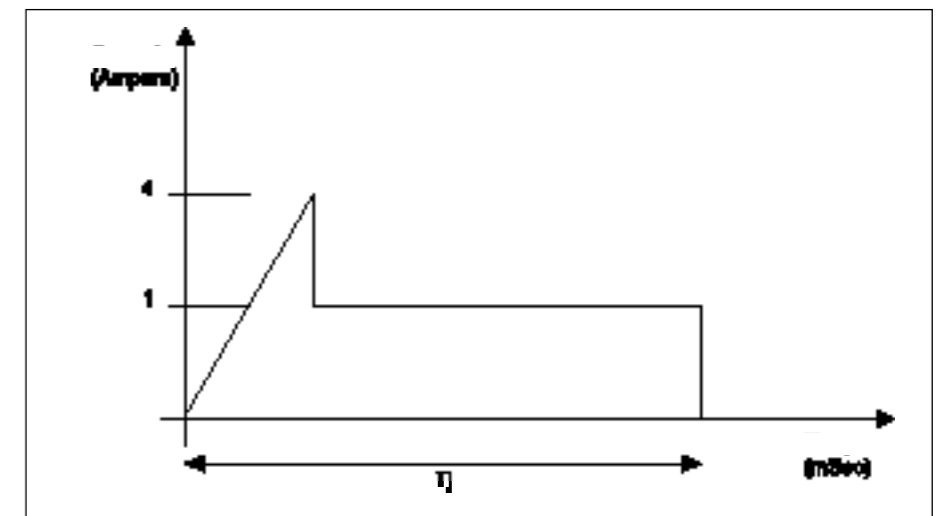

Fig. 9

3.5 NOZZLE-

3.5.1 Standard

The nozzle is clamped to the suction manifold and connected to the injectors by means of a suitable tube.

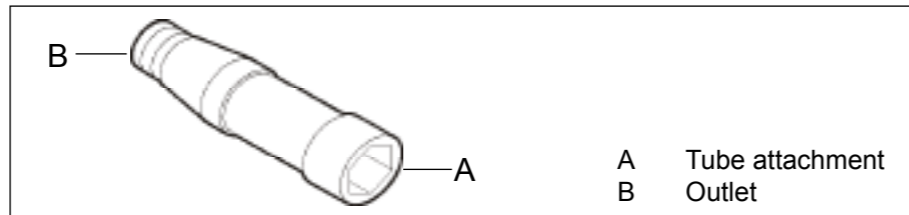

Fig. 10

Technical specifications:

Calibrated pass-through hole: Ø 4 mm
 Connection to the fuel rail: outside Ø 6 mm
 Manifold connection: M6 x 1 thread

3.5.2 Optional

The nozzle is clamped to the suction manifold and connected to the injectors by means of a suitable tube.

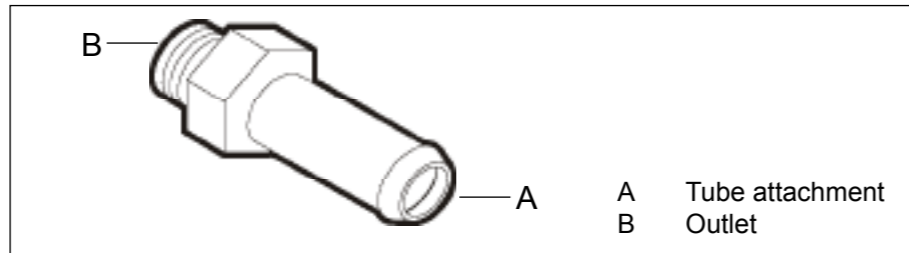

Fig. 11

Technical specifications:

Calibrated pass-through hole: Ø 4 mm
 Connection to the fuel rail: outside Ø 6 mm
 Manifold connection: M8 x 1 thread

3.6 LANDIRENZO OMEGAS CONTROL UNIT

The control and driving of the system are effected through the Electronic Control Unit (ECU), which is, therefore, considered the "brain" of the system.

The main functions of the gas ECU are:

Measuring the engine original input signals:

- Petrol injectors
- Water temperature (engine crankcrane)*
- Engine RPMs
- Battery voltage

Measuring the system input signals:

- Gas pressure
- Water temperature on the external engine cooling circuit*
- Gas temperature
- Fuel level sensor

Driving the system outputs

- Petrol/gas switch
- Driving the solenoid valves
- Driving the gas injectors
- Deactivating the petrol injectors
- Serial communications with the fuel switch
- Indicating the fuel level
- Operating the buzzer
- Controlling the components and diagnostics
- Communicating with the interface (PC) software.

When the software is updated, it is always possible to update the program resident in the ECU through the PC. It is also possible to modify several calibration parameters at any time.
 (* alternatively)

Technical specifications:

	OMEGAS	OMEGAS PLUS
Weight	680 g.	630 g.
Electrical supply:	8 ÷ 16 V	8 ÷ 16 V
Functioning temperature	-40 ÷ +100 °C	-40 ÷ +105 °C
Maximum absorption of power:	10 A	4 A
Flash memory:	128 Kb	128 Kb
Processor speed (PLL):	50 Mhz	40 Mhz
Injector drivers:	until 8	until 8
Solenoid valve outputs:	2	2
Connector	IP54	IP59K
Type approval	E3 67R-016002	

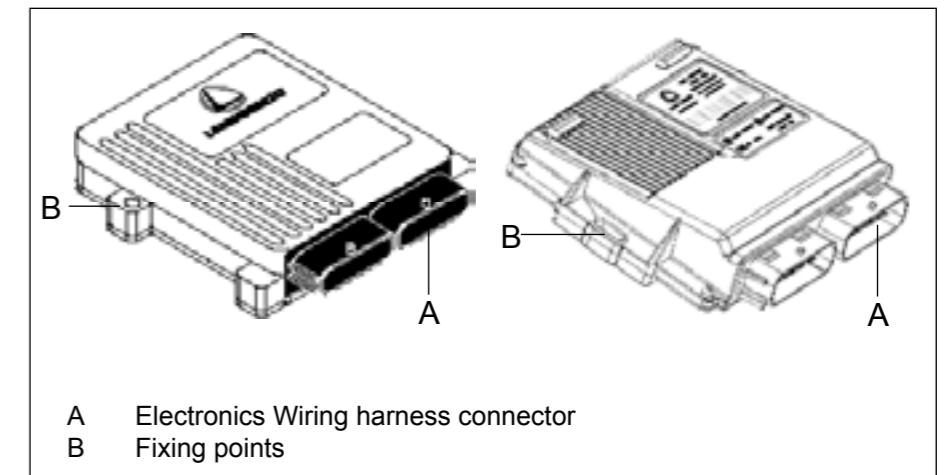

Fig. 12

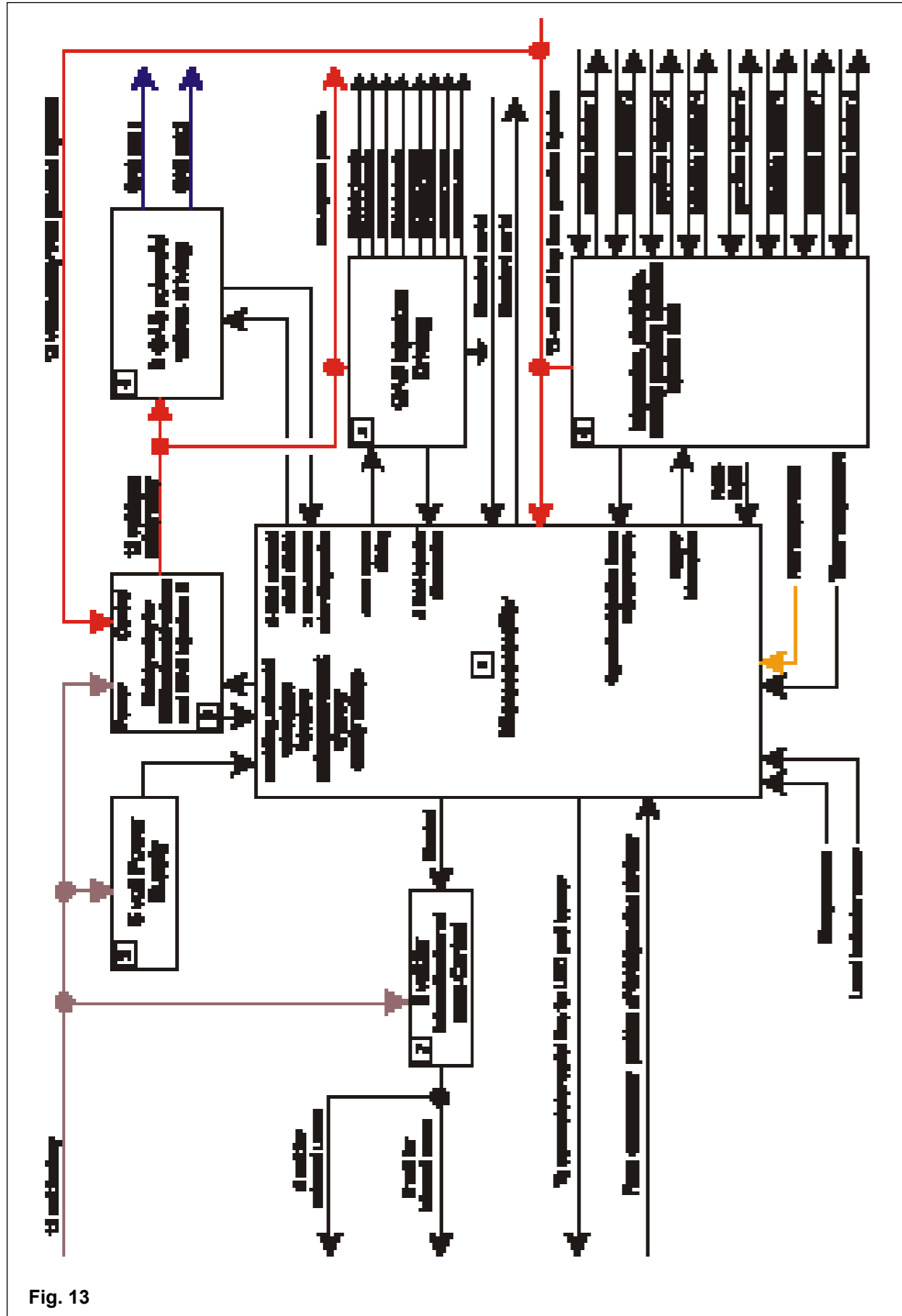

Fig. 13

3.7 PETROL/GAS SWITCH

- A) Gas/petrol push button
 - indication of the fuel in use through the two luminous LEDs (B) and (C);
 - pressed for 5 seconds with the root key inserted allows direct starting with gas.
- B) Green LED
 - constantly lit: indicates normal gas operation;
 - rapid flashing: indicates the state of waiting for the automatic Petrol/gas switch to gas during the start-up phase (which is always with petrol);
 - slow flashing: indicates a system malfunction during the use of gas (diagnosis);
 - lit simultaneously with the yellow LED: indicates Petrol/gas switch back to petrol. This mode is also indicated by a buzzer also activated by the Petrol/gas switch.
- C) Yellow LED
 - constantly lit: indicates petrol operation.
- D) Series LEDs
 - indicate the level of gas (divided into fourths) in the tank; the red LED indicates reserve.
- E) connector
 - connects the Petrol/gas switch to the WIRING HARNESS coming from the LANDIRENZO OMEGAS control unit.

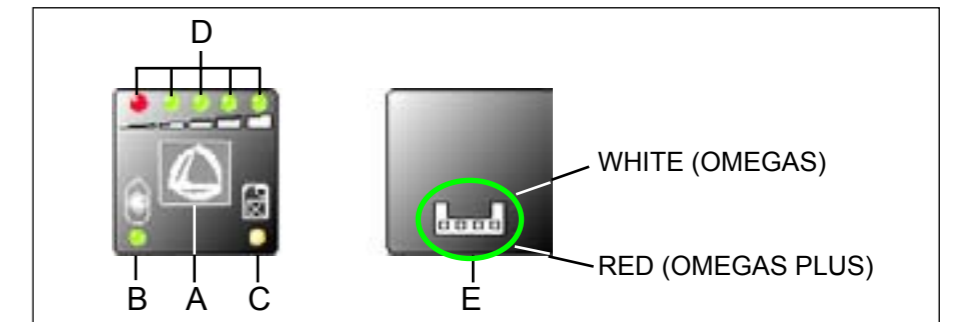

Fig. 14

LANDIRENZO OMEGAS is equipped with a self-diagnostic system that uses the green LED (B), the same one which indicates gas operation, to signal any malfunctions or the acquisition of incorrect data by the system. When one of these abnormal conditions occurs, the green LED will begin to flash slowly during gas operation. In the event of a malfunction occurring which could affect the correct operation of the engine, the LANDIRENZO OMEGAS control unit will automatically switch operation from gas to petrol. This condition will be reported by the lighting of the yellow LED, the slow flashing of the green LED and a buzzer activated by the Petrol/gas switch.

3.8 WIRING HARNESS

3.8.1 Injection System

All the necessary electrical connections are integrated into a single cable. The 56-pin main connector must be connected to the ECU.

DESCRIPTION	PIN		PIN	DESCRIPTION
GAS INJECTOR 1	26		55	
GAS INJECTOR 2	27		56	
GAS INJECTOR 3	28		57	
GAS INJECTOR 4	29		58	
POSITV GAS INL	24		52	POSITV GAS INL
POWER GND	29		51	POWER GND
GAS INJECTOR 5	22		50	+16V STABILIZED
GAS INJECTOR 6	21		49	IGNITION
GAS INJECTOR 7	20		48	SERIAL SWITCH
GAS INJECTOR 8	19		47	MAP OUTSIDE / PRESS. MANIFOLD
INPUT OPTIONAL	18		46	GAS PRESSURE / DIFFERENTIAL
GAS SERVICE	17		45	RX SERIAL
LOCK GROUND	16		44	TX SERIAL
12V BATTERY	15		43	12V BATTERY

DESCRIPTION	PIN		PIN	DESCRIPTION
DISCONNECT INJECTORS 8 SIDE ECU	14		42	DISCONNECT INJECTORS 8 SIDE INL
DISCONNECT INJECTORS 7 SIDE INL	13		41	12V UNDER KEY
DISCONNECT INJECTORS 7 SIDE ECU	12		40	RPM
DISCONNECT INJECTORS 6 SIDE INL	11		39	GAS TEMPERATURE
DISCONNECT INJECTORS 6 SIDE ECU	10		38	SENSOR LEVEL
DISCONNECT INJECTORS 5 SIDE INL	9		37	TPS
DISCONNECT INJECTORS 5 SIDE ECU	8		36	WATER TEMPERATURE
DISCONNECT INJECTORS 4 SIDE INL	7		35	VOLTAGE SUPPLY SENSOR
DISCONNECT INJECTORS 4 SIDE ECU	6		34	OUT LAMBDA 1
DISCONNECT INJECTORS 3 SIDE INL	5		33	IN LAMBDA 1
DISCONNECT INJECTORS 3 SIDE ECU	4		32	OPTIONAL LAMBDA 3
DISCONNECT INJECTORS 2 SIDE INL	3		31	
DISCONNECT INJECTORS 2 SIDE ECU	2		30	
DISCONNECT INJECTORS 1 SIDE INL	1		29	DISCONNECT INJECTORS 1 SIDE ECU

Fig. 15

CONNECTOR DESCRIPTION	
1	SICMA 2 plug female connector BLACK 56-way
2	AMP SUPERSEAL series male 4-way. 2-way female port connector
3	Fuseholder N.B. insert the 20-Ampere blade fuse in the fuse box.
4	2-way AMP female Mini-timer connector, female port.
5	
6	
7	
8	
9	
10	
11	
12	JST 4-way male connector female port.
13	SICMA 2 2-way male connector female port.
14	AMP ECNOSEAL 10-way female connector female port.
15	
16	BOSCH 4-way female connector female port.
17	JST male connector female port
COMPONENT DESCRIPTION	
A	connector

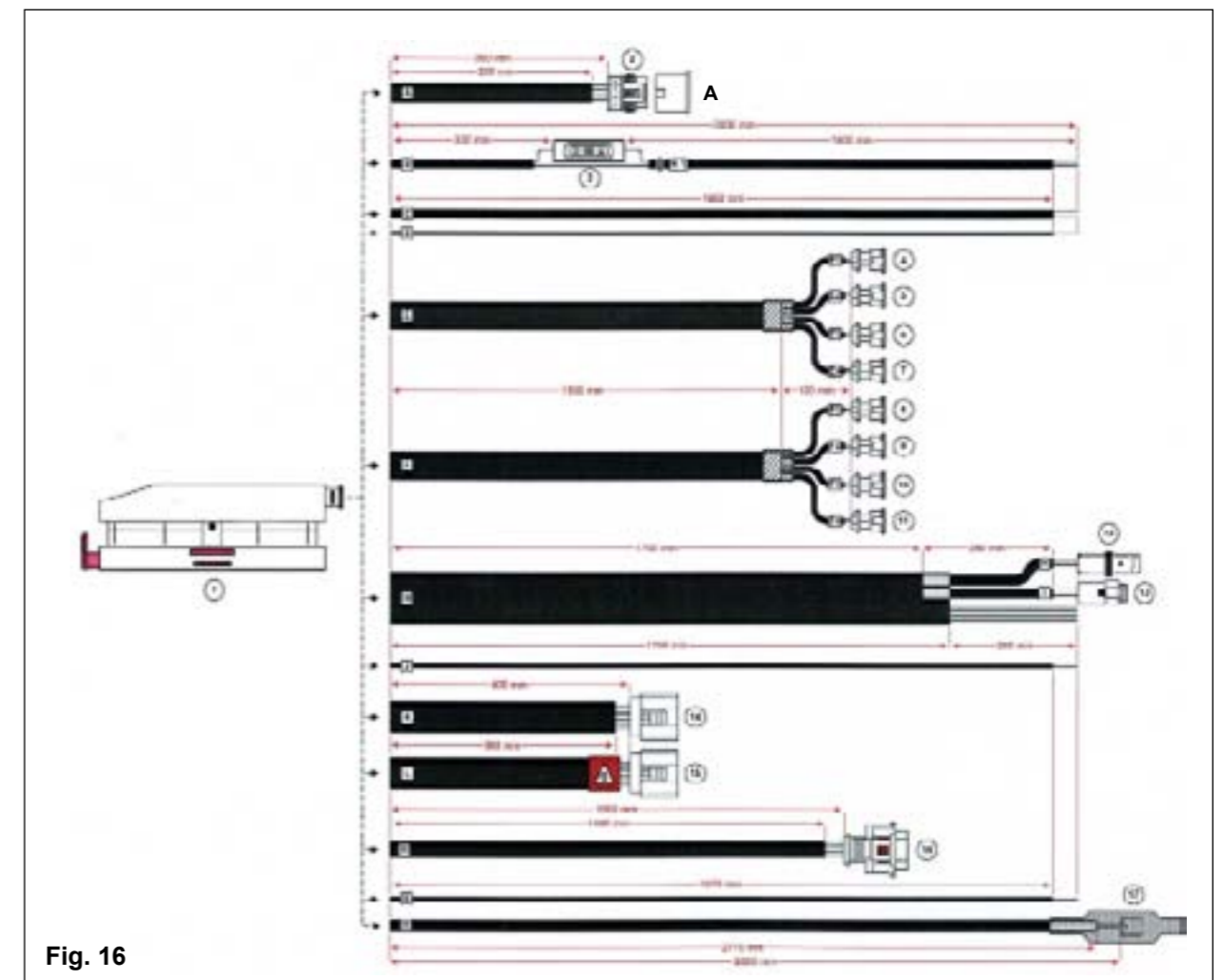

Fig. 16

3.8.2 Injector Cutting Harness

There are three available injector cutting harness types for 4-cylinder engines and two injector cutting harness types for 6-cylinder engines.

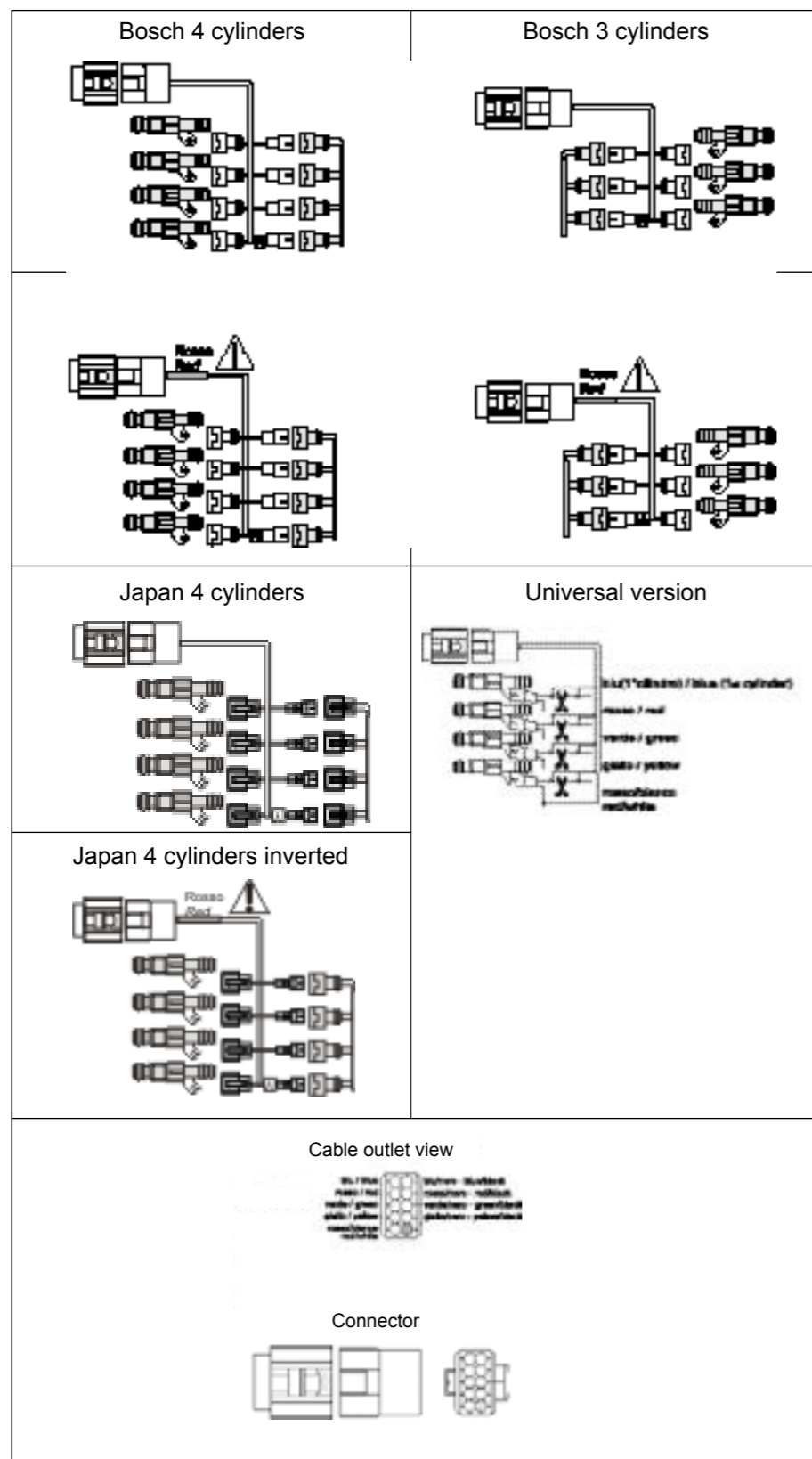

Fig. 17

For the universal injector cutting harness connector, follow the instructions shown in figure.

CHAPTER 4

INSTALLATION

4.1 EQUIPMENT/TOOLS REQUIRED

- 10 Nm torque wrench.
- Assorted open-ended spanners.
- Electrician's shears.
- Assorted cutters.
- Tap wrench.
- Male M8 x 1.
- Double meter tape.
- Multimeter.
- Personal Computer. Minimum requirements (Laptop): Pentium processor, 32 MB RAM, 5 MB of space available on the hard disk drive, monitor with VGA 800 x 600 resolution, Windows 98 SE, 2000, XP.
- Wire-stripping pliers.
- Lifting bridge.
- Assorted drill bits: from 4 to 8 mm.
- Gas or foam leak detector.
- Scanner/instrumentation for diagnosing the vehicle's original ignition and fuel system or oscilloscope.
- LANDIRENZO OMEGAS interface software.
- Portable electric or pneumatic drill.

The above-mentioned equipment must be adequately maintained and, when necessary, calibrated following the manufacturer's specifications and timing.

4.2 ASSORTED WORKSHOP MATERIALS

- Grease
- Shrink-wrap sheathing
- Radiator coolant liquid
- Adhesive tape
- Sealant for threads

4.3 BEFORE STARTING THE INSTALLATION

Carry out the following checks on the engine:

- Air filter
- Using the oscilloscope, check that the status of the cables, spark plugs and coils conform to OEM specifications.
- The suction and exhaust valves, even if mechanical, must have the play specified by the OEM.
- The catalytic converter must be in good operating condition.
- The Lambda probe must be in good condition.
- Carry out a self-diagnosis of the vehicle.

Carry out any adjustments and/or modifications required by the above-indicated diagnostic procedures and, if necessary, replace the defective components.



N.B. At increasing respective heights, mount the pressure reduction unit, filter and injector rail, to avoid oil, present in LPG, collecting in the injector rail.

4.4 ASSEMBLING COMPONENTS

4.4.1 Notes relating to all components involved in handling gas

- Fix all gas components in the engine compartment, in the positions shown.
Attach the components directly to the bodywork of the vehicle or, indirectly, using the supports provided in the kit.
- Do not fix elements in the area of the passenger compartment ventilation system; also make sure that the component is not installed near the air intake of the passenger compartment ventilation system.
- Do not fix the component less than 150 mm from the exhaust system or from the silencers. If this is not possible, it will be necessary to install a guard made of metal or equivalent material, with a thickness not less than 1 mm. Even in this case, do not install the component at a distance of less than 75 mm from the exhaust system.
- Make sure not to create folds or tight curves in the connecting tubes.

4.4.2 Closing and opening the CLIC-R clamps on the gas tubes

The fittings, tubes and clamps used are in strict correlation for the purpose of guaranteeing a leak-free connection. Special clamps are used on the gas tubes; pliers should be used to attach and remove them.

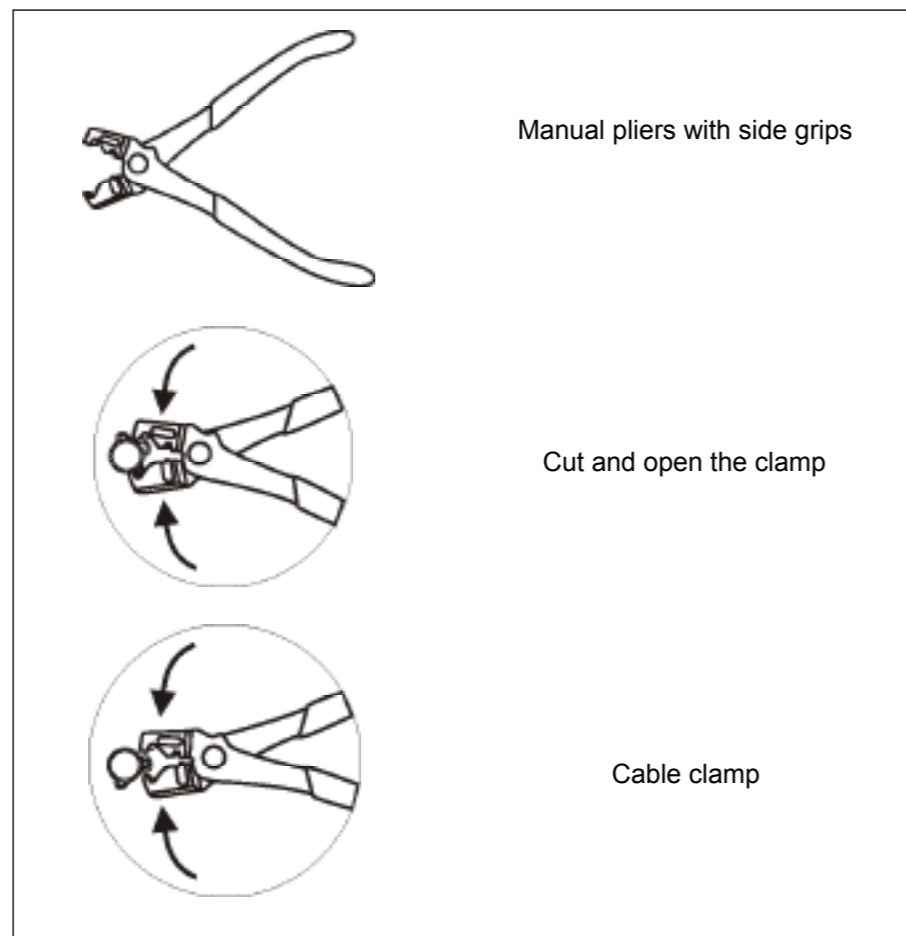

Fig. 18

4.4.3 Vaporizer/pressure regulator

The following instructions must be observed for the installation of the reducer:

- Fix the reducer so as to make adjustment and maintenance easy.
- Attach the reducer/atomizer to the body of the vehicle, **DO NOT** under any circumstances attach it to the engine or other components in their turn attached to the engine.
- Position the water circulation tubes as shown in figure.
- The fittings on the pressure reducer can be rotated to create the most convenient positions for the water tubes.
- Using the clamps, make sure the heating tubes are connected to the water connections of the reducer as shown in figure.
- The other end of the water tube must be connected in parallel with the tubes of the vehicle heating system, by means of T junctions.

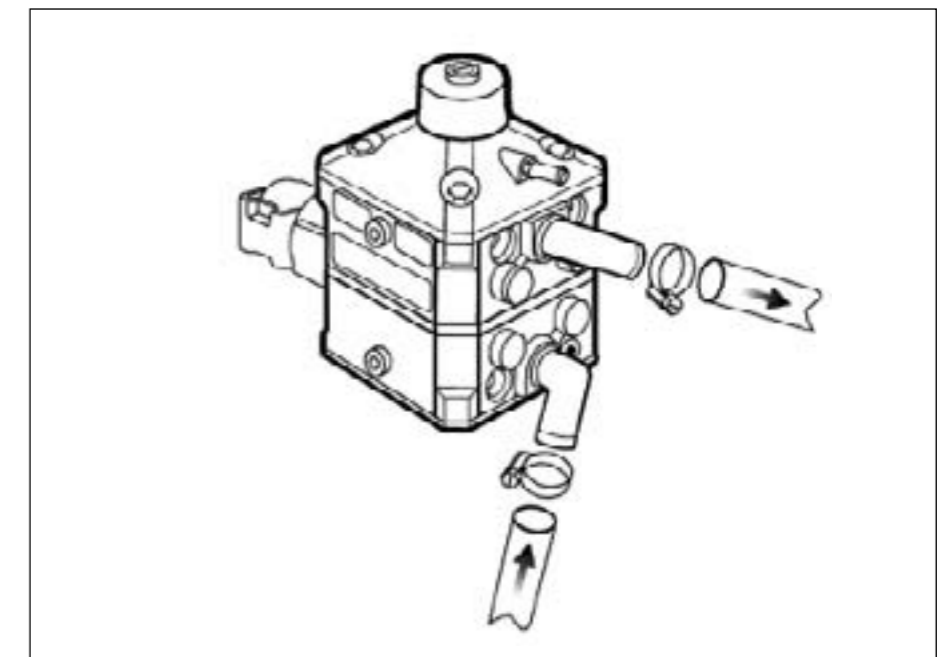

Fig. 19

- Take care not to create kinks or tight curves when connecting the tubes. Good heating is necessary so that the LPG will evaporate.
- Fix the reducer below the level of the radiator so as to avoid the accumulation of air bubbles in the cooling system.
- Thoroughly clean the LPG tank and tubing before assembling in order to avoid the accumulation of dirt inside the reducer.
- When assembly is complete, start the engine and allow it to reach normal operating temperature, making sure that there are no water leaks and the reducer heats up quickly.
- Every time the cooling system is drained, it will be necessary to reset the level of the cooling system based on the OEM's specifications, making sure to eliminate any air pockets that could prevent the coolant liquid from circulating inside the reducer.

4.5 FILTER UNIT

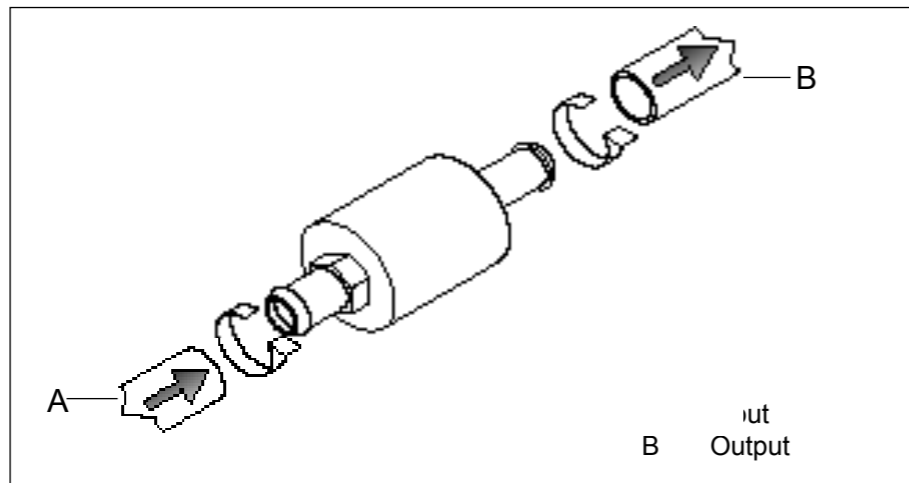

Fig. 20

Follow the procedures for installing the filter unit, as shown below:

- Place the filter unit as close as possible to the injector rail and not too far from the reducer. The maximum length of the tube between reducer and filter is 70 cm, while that between the filter unit and injector rail is 25 cm.
- Avoid the gas tubes passing close to thermal conduction points, in order to protect them and not heat the gas.
- Fit the gas tubes as shown in the figure. The 14-mm tube A on the input coming from the reducer and the 14 mm tube B on the output that brings the gas to the rail.

4.6 INJECTOR RAIL

Follow the procedures for installing the injector rail, as shown below:

- The injector rail has two threaded M6 holes for fitting the unit using the support provided in the kit.
- It will be necessary to place the tubes with the 6-mm interior Ø on the injector output to connect the injector with the nozzle placed on the suction manifold.
- There is a tight correlation between the location of the injector rail and the nozzles.
- Place the injector rail close to the suction manifold in such a way that the connection tubes can be as short as possible and so that the nozzles can easily be connected without kinks.

- **The injector rail/manifold tubes must be no longer than 18 cm.**
- **The difference in length between the tubes must not be greater than 2 cm.**
- **Pay particular attention to the correspondence of the injectors indicated by the letters 'A, B, C and D' located on the injector with the sequence of wires for the interruption of petrol injection.**



It is essential that the injector marked with the letter 'A' feeds the cylinder on which the blue-blue/black wires are used to interrupt petrol injection (therefore, the first or the fourth).

All the others go in sequence.

- In interrupting the petrol (in the event that the "universal" cable is used) pay attention to the directionality of the wire connections.

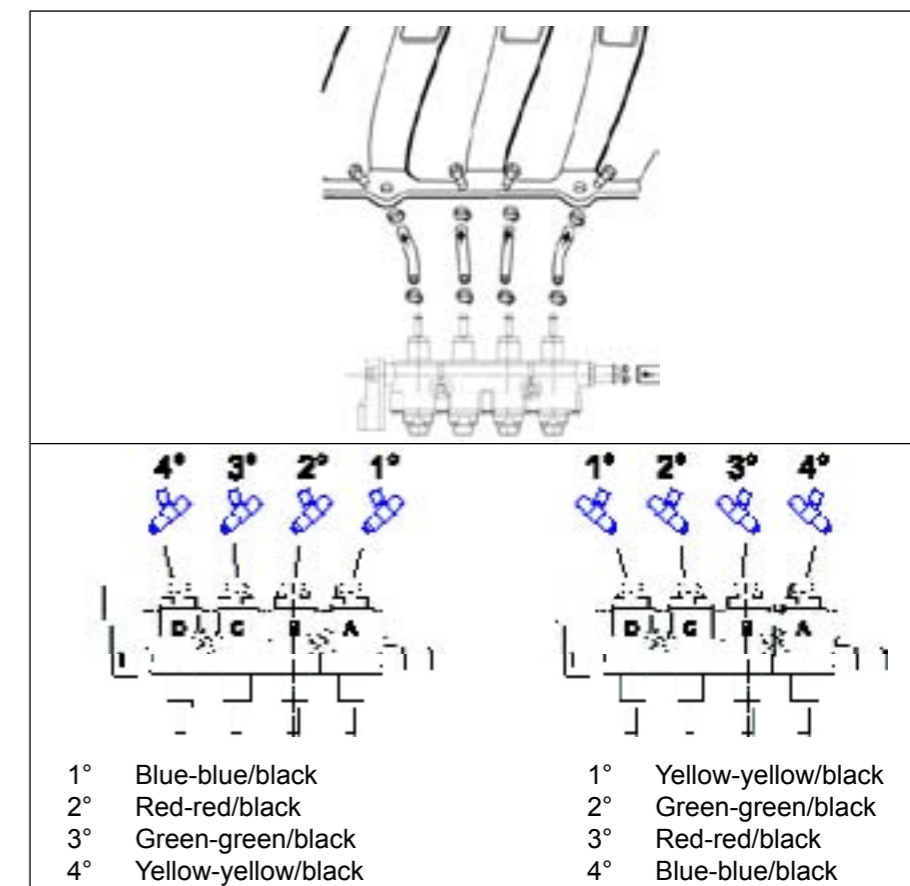

Fig. 21

4.7 NOZZLES

The correct installation of the nozzles is crucial for the good operation of the engine. These must be installed exclusively with the prior removal of the manifold.

- Dismantle the suction manifold taking care not to damage the gasket. Carefully note the connections and assembly of all the components installed on the manifold.
- Following the instructions provided on the "vehicle cards," make the holes for installing the nozzles on the manifold.
- In the event that no vehicle card is available to define the positions of the nozzles, place them as close as possible to the petrol injector.
- Mark the points to be drilled.
- Before making the holes, punch the exact points where the holes will be made.

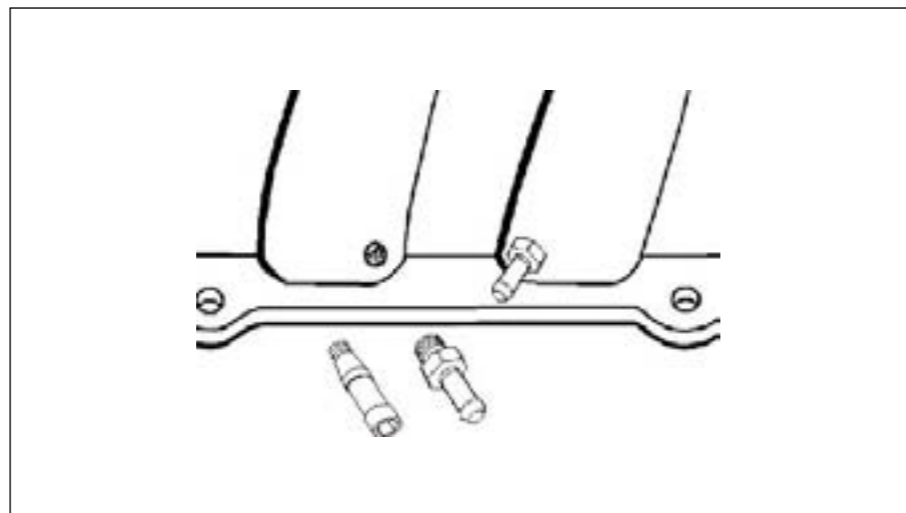

Fig. 22

- Apply grease to the point of the drill bit so as to avoid spreading swarf, then drill using a 7-mm bit if the suction manifold is made of aluminum alloy. In the event that the suction manifold is plastic, use a 6.8 mm bit. During drilling, it is important to keep the drill in a perpendicular position with respect to the surface to be drilled.
- Tap a thread with a male M8x1.
- Carefully clean the suction manifold and remove all the drilling swarf.
- Take care not to damage the threads in tightening the fittings.
- If fitting to a plastic collector, place a 1.5 – 2 mm aluminium washer between the nozzle and the collector
- Use a drop of brake thread sealant in the coupling to improve the grip.
- Reassemble the suction manifold and use new manifold gaskets, if necessary. Reassemble all the components previously removed during the course of the dismantling operation.

4.8 CONNECTION TUBES

4.8.1 Engine system

Below is a general layout of tubes used in this system.

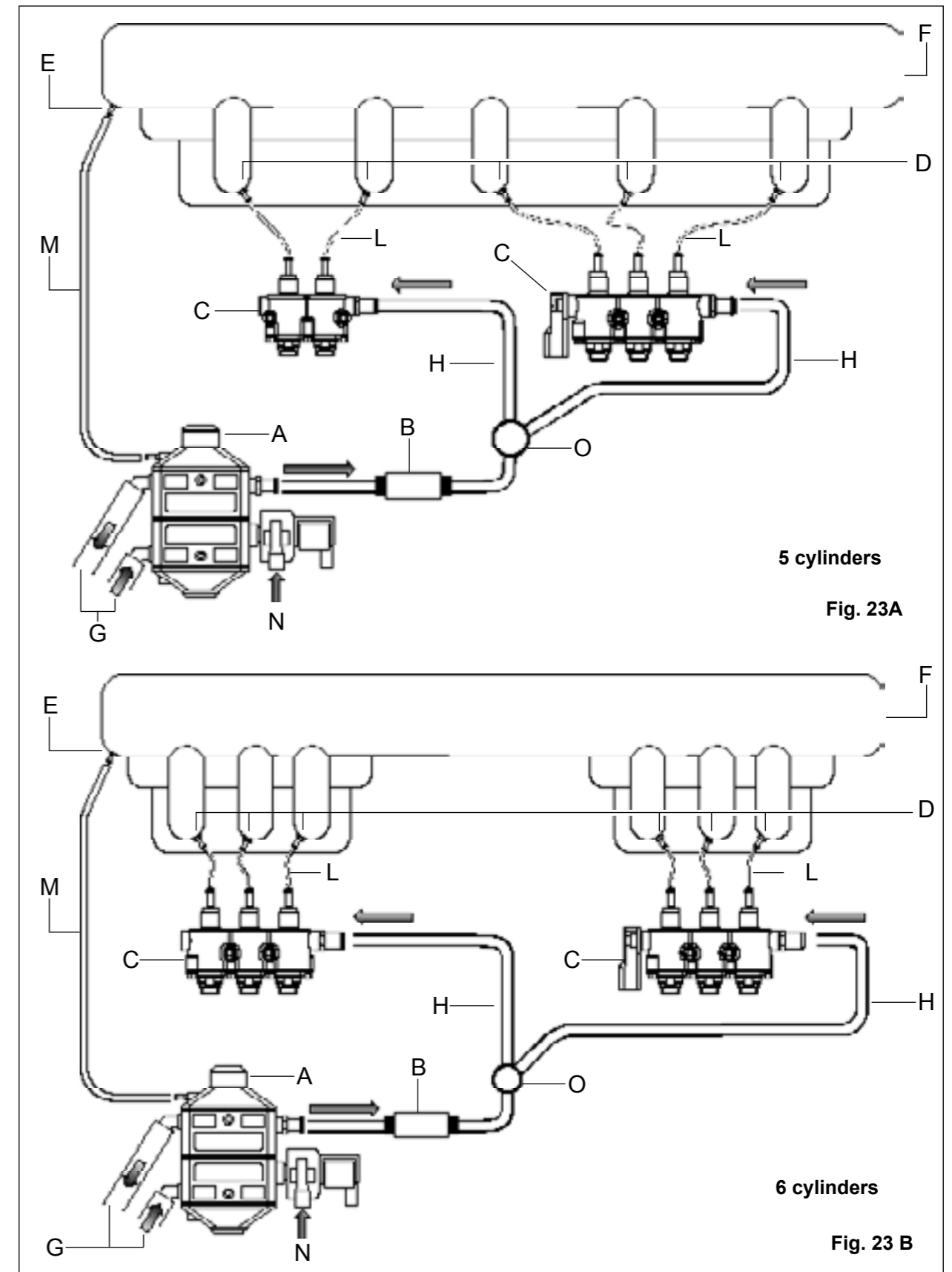

5 cylinders

Fig. 23A

6 cylinders

Fig. 23 B

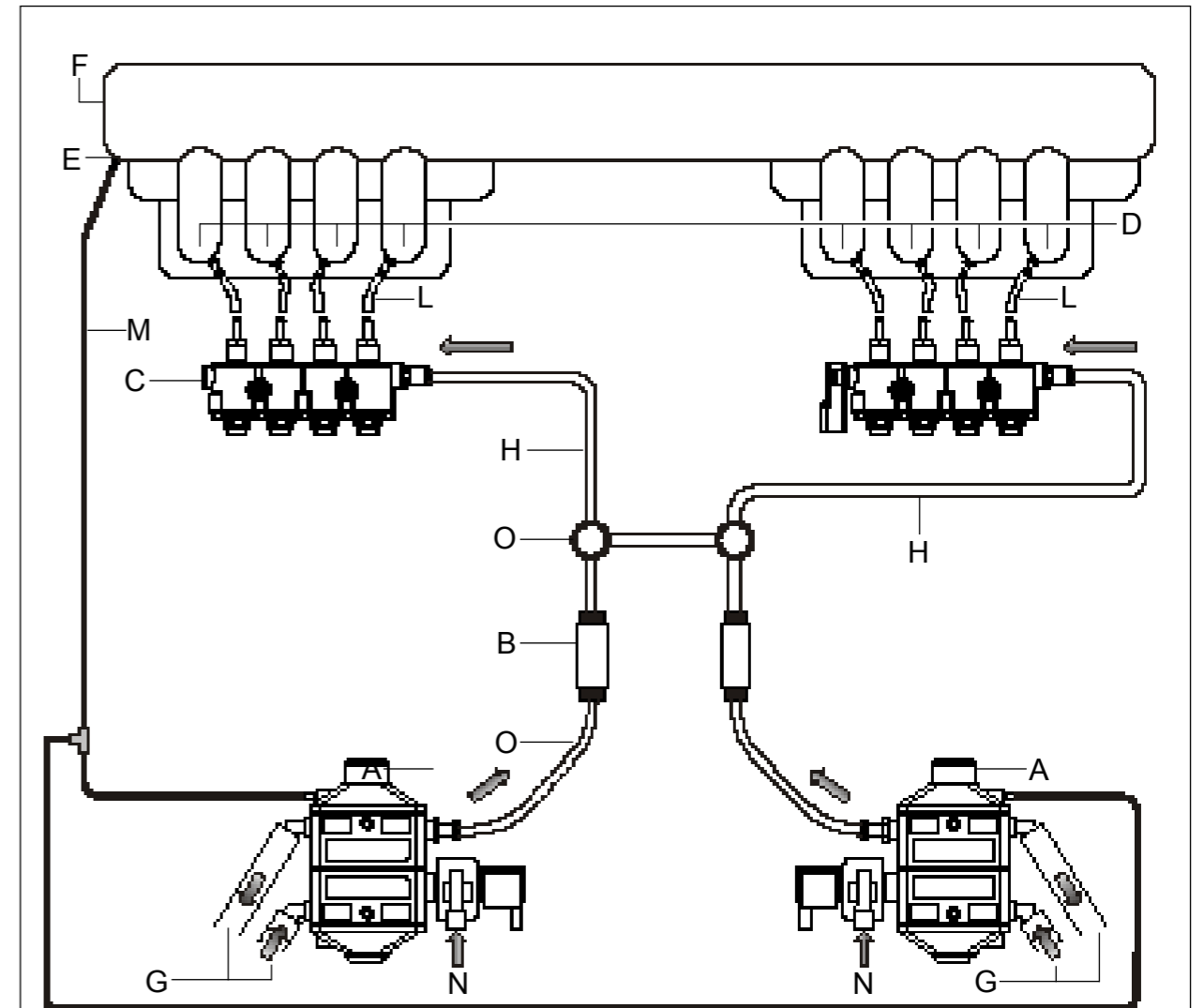
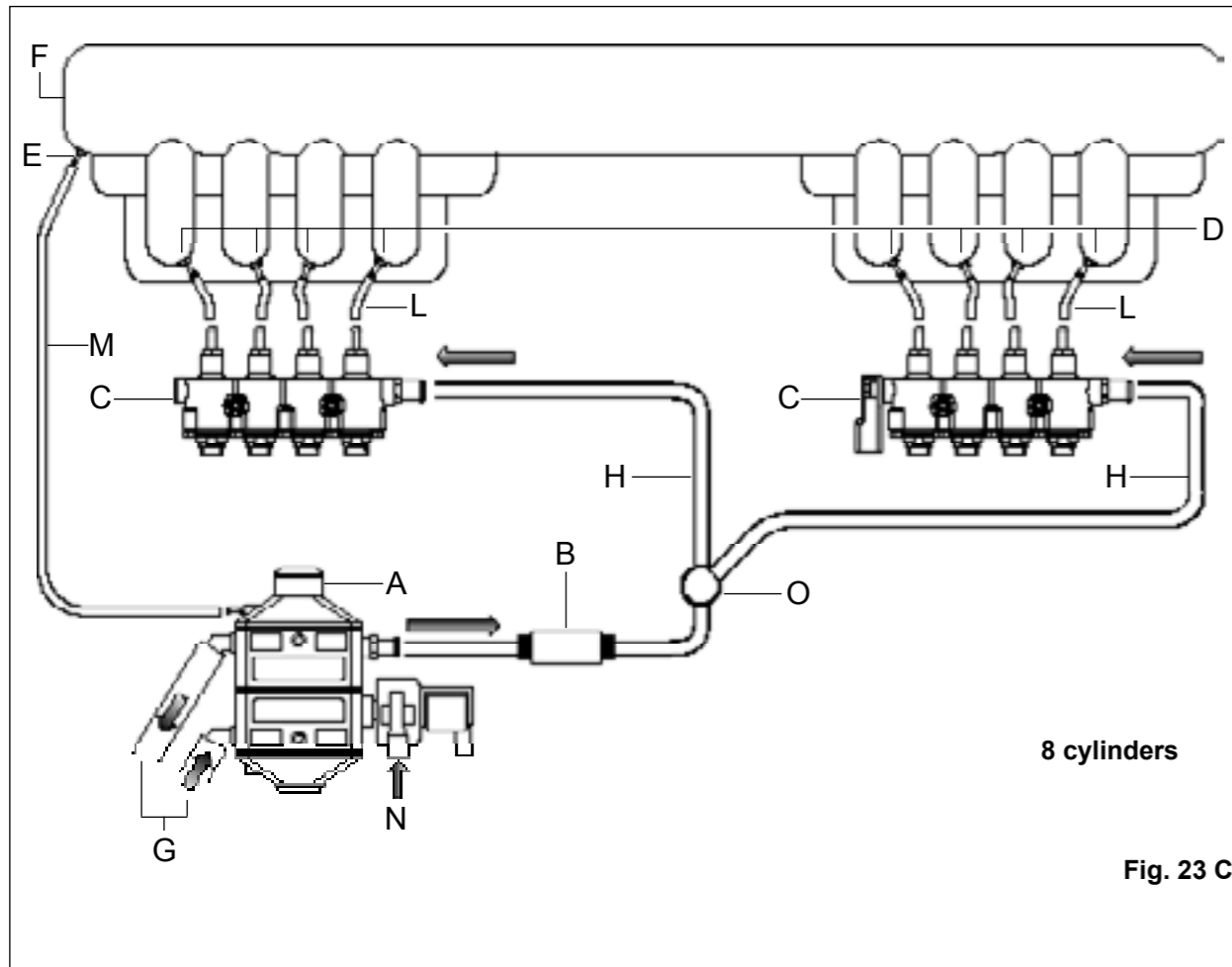

Legend:

- A. Pressure regulator
- B. Filter unit
- C. Injector Rail
- D. Nozzles
- E. MAP fitting
- F. Suction manifold
- G. Radiator heating tubes
- H. Gas tube
- L. Gas tube
- M. MAP tube
- N. Gas inlet
- O. Three ways fitting

Technical specifications:

Water tube G:	inside Ø 15, outside Ø 23
Gas tube H:	inside Ø 14, outside Ø 22
Gas tube L:	inside Ø 6, outside Ø 13
Compensation tube M:	inside Ø 5, outside Ø 10
LPG gas tube type approval N°:	E4 67R-010128

4.9 ECU

- Install the ECU in the engine or passenger compartment in the position shown on the relevant car sheet.
In the event that no car sheet is available, attach the control unit directly to the body of the vehicle in a vertical position or rotated 90°, as shown in the figure.
- Position the ECU far away from heat sources, such as the exhaust manifold, radiator, etc., and protect it from water infiltration.
- Place the ECU so as to allow easy access for connecting and disconnecting the connector of pre-assembled Wiring harness loom A.
- Connect the cable connector by pressing it on the ECU and with locking lever B completely pulled out.
- Lock the connector to the ECU by pressing lever B inwards.

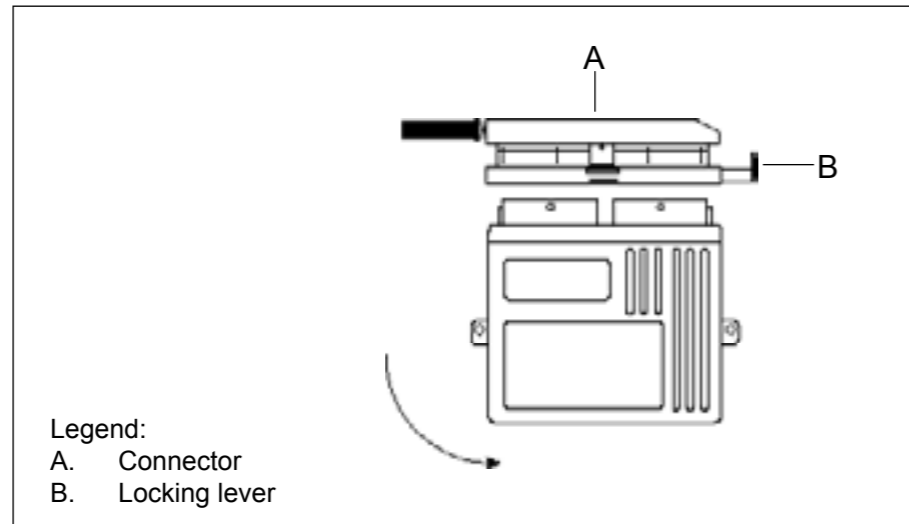

Fig. 24

4.10 PETROL/GAS SWITCH

- Install the Petrol/gas switch on the dashboard in the passenger compartment in a position that is visible and accessible to the driver.
- Make a 12 Ø hole.
- Connect the cable coming from the gas ECU control unit to the back of the Petrol/gas switch.
- Attach the Petrol/gas switch using the Ø 12 bi-adhesive provided.

4.11 ELECTRICAL CONNECTIONS

The electrical connections must:

- Follow the layout in the installation manual or car sheets.
- Be kept well away from heat sources such as exhaust manifolds, radiator, etc.
- Follow the path of the original vehicle cables and, if necessary, secure the LANDIRENZO OMEGAS Wiring harness with clamps to protect the system from accidental tearing during engine operation.
- Be kept far away from moving parts such as fans, belts, etc.
- The connectors and cables must be kept far away from high voltage wires such as spark plug leads.
- Solder each connection and seal it with heat-shrink sheathing.
- To find the +12 V battery signal for LANDIRENZO OMEGAS, see the diagram in the "Vehicle Installation/Conversion Manual."
- Connect the earth cables to a reliable socket such as the negative battery pole or the vehicles original earth.

4.11.1 Engine system aspirated with IG1 reduction unit

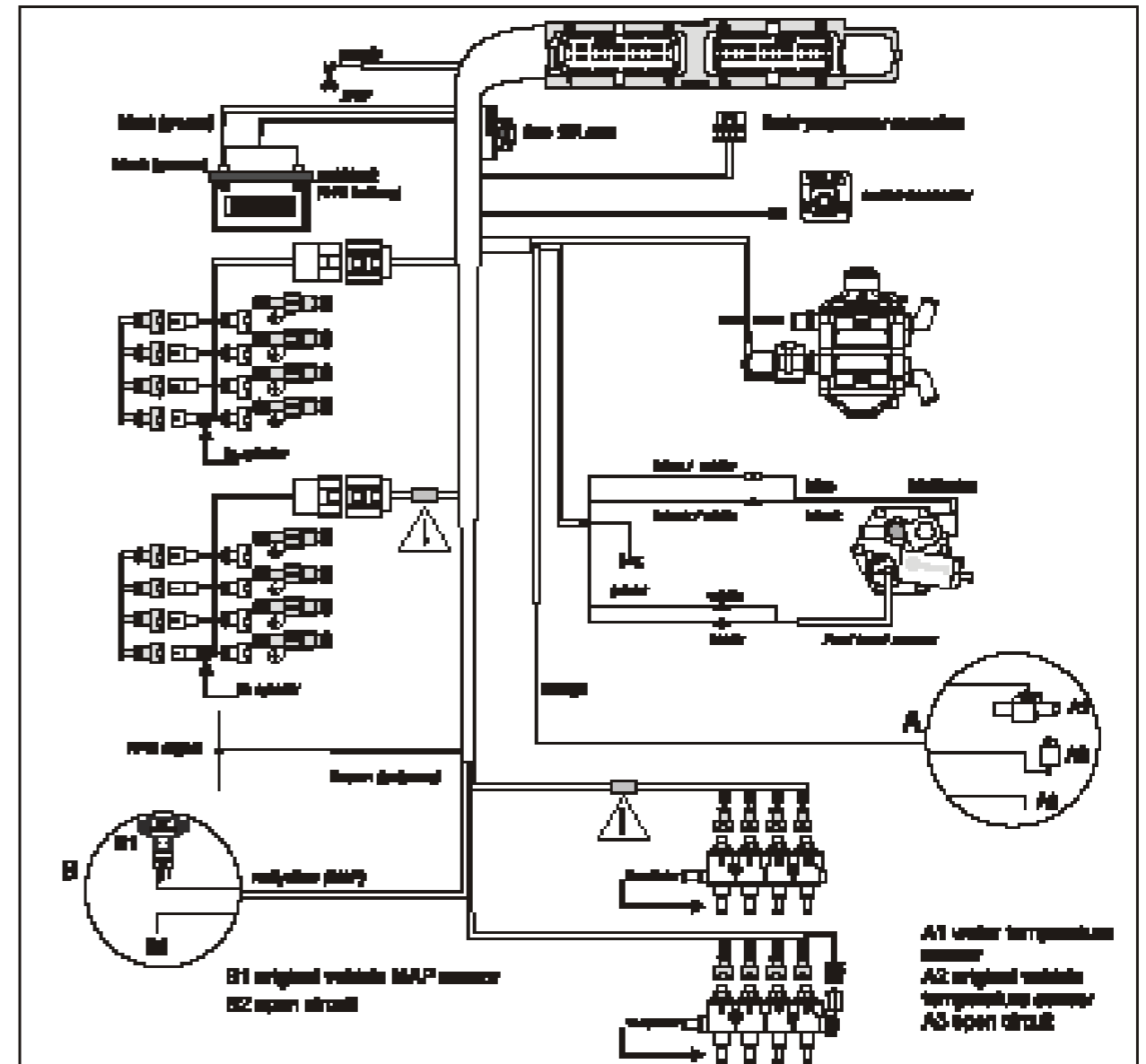

4.11.2 Engine system aspirated with two IG1 reduction unit

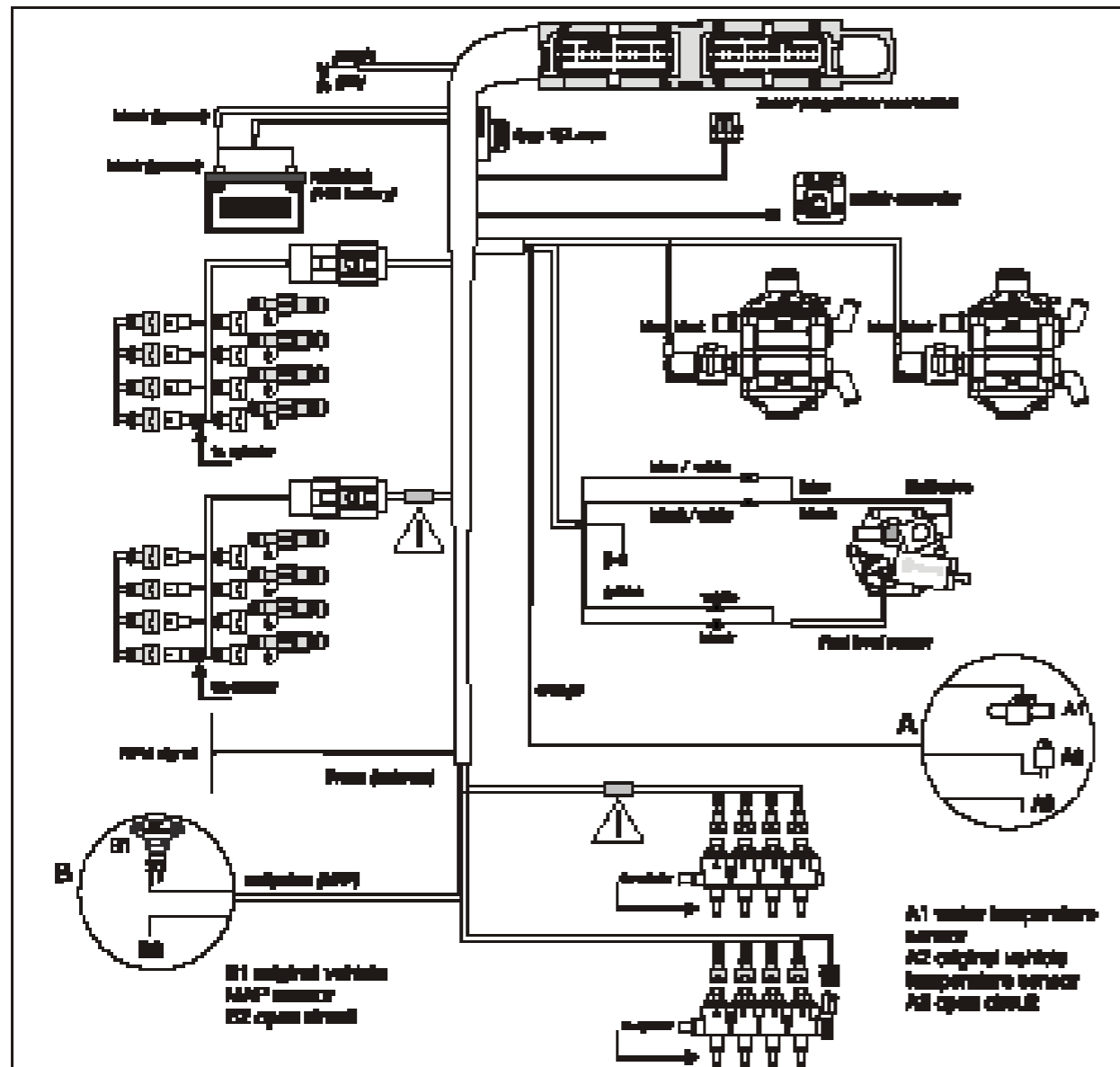

4.12 RECOMMENDATIONS

To get the best from LPG, the engine of your vehicle has to be correctly tuned up and it has to be maintained (for mechanical and electrical requirements). In addition to the O.E.M. maintenance for the vehicle, it is recommended to:

- Every 20.000 km: the substitution of the spark plugs, the check of the exhaust gas with analyzer, the check / substitution of the air filter, the check / substitution of the gas filter, the check of the good functioning of the lambda sensor.
- Every 30.000 km: check of valves slack (valves play).

We recommend to check the good functioning of the petrol injection system every 4.000 / 5.000 km, driving for some kilometres on petrol.

It is important to keep the petrol level not under 1/4 of the tank capacity to not damage the good functioning of the petrol pump.

LPG has a particular smell so that it is simple to identify leaks; in case of gas leaks it is necessary to switch off the engine, switch off the light dashboard, change over petrol the Landi Renzo switch/indicator, do not smoke, verify that there are no ignition source near the vehicle. When the LPG smell disappears, isolate the tank. Now it is possible to use the vehicle running on petrol and we suggest to you to check the system to an installer. In case of the smell of LPG does not disappears, switch off the engine, isolate the tank, do not switch the engine no more before the verify of your installer.

4.13 TANK

Remember these simple cautions: switch on the hand brake, switch off the engine, switch off the lights dashboard, do not smoke.

FOR SAFETY REASONS, TANK HAS NOT TO BE FILLED FOR OVER THAN 80% OF ITS CAPACITY (I.E. WITH A TANK OF 80 LT., IT IS POSSIBLE TO STORE ABOUT 64 LT).

The limit of the filling it is ensured from the multivalve placed on the LPG tank. In case of a filling over the 80% , we recommend to not leave the vehicle parked at the sun for many hours, before you don't finish the fuel in excess.

LPG tank has a lifetime of 10 years (European regulation). Tank manufacturing date it is normally placed near the multivalve.

4.14 IN CASE OF ACCIDENT

The main cautions are equal to the ones for a petrol powered vehicle, remember always to switch on the hand brake, switch off the engine, (automatically it will be activated a safety device that stops the flow of the gas to the engine), switch off the lights dashboard, and if possible, isolate the tank closing the valve (A) placed over the multivalve of the LPG tank.

CHAPTER 5 REMINDER



Before installing the device check that the vehicle functions correctly using petrol and/or that no errors are stored in the petrol injection control unit, and make any repairs necessary.

The operating pressure of the reduction unit second stage displayed on the PC with the vehicle operating using gas at idle: 0.95 bar (LPG), 2 bars (CNG) ±3% normally aspirated engines 1.45/1.5 bar (LPG), 3.5 bar (CNG) turbo engines.

The system changes back to petrol every time the pressure falls more than 0.5 bars below the operating pressure.

DIAGNOSIS stores a series of errors that is kept in the memory until deleted manually.

All options should be left enabled.

Connection to the Lambda sensor is optional, but where possible should also be carried out.

The "gas injector supply voltage" is vital for the device to function correctly. This value can be read in the "Display" window F2. The optimal range is: 8 - 16 Volts

The engine changes back to petrol when the gas is finished if the switch indicates reserve and the pressure falls below a preset threshold; changing back for any other reason stores an error in diagnosis (diagnostics section).

(*) NOTE

Where carburation modification is suggested in the following pages, on vehicles fitted with the OBD system, although not specifically mentioned, this means using a diagnostic tester to measure the parameters needed to establish correct carburation. Specifically, the following parameters should be displayed:

- slow corrector
- fast corrector
- Lambda sensor
- ignition advance

In addition, if the petrol control unit saves any errors, the error code and the condition in which the error occurred should be written down.

5.1 INSTALLATION

SYMPTOM	CAUSE	SOLUTION
An error message appears on the PC in any condition.	Can be caused by several factors.	Check the error code in the table at the end of this manual.
File not found in archive.	The control unit is not compatible with the file sought.	The program automatically recognises the type of control unit used. It is probably trying to use a file for 3-4 cylinders on a 5-6-8 cylinder control unit, or vice versa.
Control unit programming stops at a particular percentage value.	Internet Explorer 5.5 or higher is not installed on your PC.	Install the Internet Explorer 6.0 update, on the CD, or a more recent version if you have one.
A file cannot be loaded to the control unit, a message window showing "ERRDR 01 or 03" appears.		Check the error code in the table at the end of this manual.
	The BLACK wire, corresponding to pin 22 for the 3-4 cyl control unit and to pin 16 for the 5-6-8 cyl control unit, is not connected.	Two wires provide the negative connection to the control unit. Connect both to the negative terminal of the battery.
Control unit program does not start, nothing seems to be working.	The LR Omegas control unit is in standby.	Disconnect the fuse on the control unit power cable. Refit the fuse and press the desired wire within 4 seconds of power being supplied to the control unit.
When control unit programming is complete a window appears asking for parameters to be updated.	The wire used is not suitable for the system installed, you have used a wire optimised for a type of gas injector that is not the same as those installed in your vehicle. The files are identified by the following letters: L (Lanzi) K (Kellin) M (Mairix). E.g.: Model_16_03_XYZ_L-K-M G_602	Press NO, exit configuration and set the parameters manually.
	The wiring used is inadequate. Our system recognises the type of gas injectors used on pin 14 of the gas control unit Pin n° 14 connected to positive (+5V) → Landi Renzo injectors; Pin n° 14 connected to earth → Kellin injectors; Pin n° 14 empty → Mairix injectors.	
In the calibration phase the petrol injection times remain at "0" and the cut-off light remains on.	Incorrect wiring installation. Petrol injectors not included.	Fit suitable wiring.

5.2 ENGINE IDLING

SYMPTOM	CAUSE	SOLUTION
The number of RPM at idle is too high or too low.	Air is circulating the compression circuit.	Replace the damaged tube.
	The vehicle idle on petrol is not properly regulated.	Regulate the vehicle idle on petrol.
With the air conditioning on the idle periodically becomes unstable for a few seconds.	The idle adjustment area is too large and the K coefficients of the points in the map where the engine runs with the air conditioning compressor on and off are not sufficiently dissimilar.	Check the K coefficients in the two different operating conditions (compressor on and off) while the engine is warm, and change the corresponding map areas accordingly.
Idle is rough (the engine "stutters") but the lambda sensor works.	The length of the injector-nozzle rail tubes is not correct.	Replace the injector-nozzle rail tubes.
	The injector rail-nozzle tubes are twisted.	
	One of the injector nozzles has a different diameter to the other ones.	Replace the wrong nozzle with the right one.
	The WAE is supplying air irregularly to one of the single cylinder tubes, and therefore a higher quantity of air is supplied at idle.	Review the installation following the instructions supplied in the vehicle sheet.
	The Lambda sensor signal is weak or incorrect.	Check functioning on petrol and replace the sensor if defective.
Carburation is so rich or lean that the engine will not run at idle speed.	The control driver of one of the injectors is not working.	Replace the OMEGAS control unit.
	The injector exclusion wiring has been connected incorrectly.	Review the injector rail wiring and injector exclusion wiring.
	Nozzles of non-standard diameter have been fitted and re-calibration has not been performed.	Install appropriate nozzles or re-calibrate.
The engine is not stable at idle, the engine speed fluctuates by several hundred RPMs.	Idle is not correctly adjusted.	Adjust the idle, ensuring that the idle areas with the air conditioning compressor on and off are well separated.
The exhaust gas analyser indicates rich or lean carburation with the engine at idle.	The petrol injector emulator in the control unit is allowing petrol through.	Replace the OMEGAS control unit.
		An injector emulator has to be installed on some vehicles. Consult the Landi Renzo technical support division.

5.3 SLIGHT ACCELERATION FROM IDLE

SYMPTOM	CAUSE	SOLUTION
The engine inizes breaks and then suddenly stalls.	The fall in RPM means that the engine operates in the medium-low part of the first column (500-700 rpm), where the K coefficients are often excessive.	Decrease the value of the K coefficient in that area of the map and check that enrichment at idle is not excessive.
	The Lambda sensor occasionally stops working and the system adjusts the richness or leanness of petrol carburation more than necessary before entering "recovery".	Check the efficiency of the Lambda sensor and replace if necessary.
The RPMs only increase with difficulty and the Lambda is stuck on rich.	The K coefficients in the transition area are too high and carburation is too rich.	In the general map, decrease the value of the cells through which the RED point transits during the acceleration phase.
The RPMs only increase with difficulty and the Lambda is stuck on rich.	The K coefficients in the transition area are too high and carburation is too rich.	In the general map, decrease the value of the cells through which the RED point transits during the acceleration phase.

5.4 HIGH ACCELERATION FROM IDLE

SYMPTOM	CAUSE	SOLUTION
Carburation is lean for a few tenths of a second after full depression of the accelerator pedal, then the Lambda sensor value remains red for a considerable time.	The values of the K coefficient during the transition are too low.	Gradually increase the K coefficients in the zone below the idle from the 2 nd to the 6 th column from the left (see the NOTE at the start of the chapter).
Carburation is lean throughout the depression of the accelerator pedal and the subsequent acceleration.	The values of the K coefficient during the transition are too low.	Gradually increase the K coefficients in the zone below the idle from the 2 nd to the 6 th column from the left (see the NOTE at the start of the chapter).
	The nozzle diameter is not correct.	The nozzles on the rail injectors have been replaced without recalibration. Recalibrate (F4). Install nozzles of the correct diameter.
	The installation requires excessively long tubes (and therefore excessive gas volumes and response times).	Review the installation, moving the rail so as to reduce the length of the rail injectors/nozzles tube and if necessary move the nozzles closer to the intake valves.
Carburation is lean during the whole depression and subsequent acceleration.	The values of the K coefficient during the transition are too high.	Gradually decrease the K coefficients in the zone below the idle from the 2 nd to the 6 th column from the left (see the NOTE at the start of the chapter).
The engine stalls or tends to stall.	Carburation during acceleration is too lean.	See solutions for the analogous case of lean carburation.
	Carburation during acceleration is too rich.	See solutions for the analogous case of rich carburation.

5.5 PETROL-GAS CHANGEOVER

To change to gas the system requires:

- The no. of RPMs must exceed the threshold value set in F1 "No. of RPMs for change threshold", under the heading "Type of change".
- The engine water temperature must exceed the threshold value set in F1 "Water temperature for change"; depending on the engine water temperature with the lock disengaged, the time set in "Petrol-gas transfer delay" must have elapsed.

SYMPTOM	CAUSE	SOLUTION
The engine does not changeover to gas	The injector excitation wiring has been connected incorrectly	Check connections.
	DIAGNOSIS has intervened.	If this is the case, check the cause of the problem, remove it (if possible) and then zero the errors in the DIAGNOSIS page.
	The "No. of RPMs for change threshold" has been set too high.	Check the value set in the program and reset to an acceptable value.
	The control unit does not read the engine RPMs.	Check the connections of the Brown wire.
	The engine RPMs signal is too weak.	Program the "type of RPM signal" parameter as "Weak". If the engine RPMs still cannot be read install a "RPM amplifier".
	The "Type of ignition" parameter has not been programmed correctly.	Change the programming unit the actual engine RPMs correspond to the reading on the program.
	The injectors do not open.	Check in "functioning diagnosis" for any accepted errors, replace the injector of control unit if defective.
The Omegas control unit is defective.	Replace the Omegas unit.	
The engine water temperature value cannot be read.	Check the electrical connections; if correct, replace the temperature sensor.	
Carburation is not optimal for several seconds after the changeover.	Faulty carburation can occur in water if the "Water temperature for change" value is set too low.	Increase the "Water temperature for change" value.
The engine changes to gas and stalls.	The solenoid valves on the tank and/or reduction unit do not open.	Check "Diagnosis" for any accepted errors, then repair the electrical connections or replace the defective solenoid valve as appropriate.
	Check the "Overlap time" in F1.	Change the "Overlap time" parameter.
	The engine carburation is too lean or too rich.	Repeat the calibration procedure.
	One or more injectors is not functioning correctly.	Check in "functioning diagnosis" for any accepted errors, replace the injectors rail if defective.
The pressure falls rapidly.	Check the pressure reducer, the efficiency of the gas filter, and for any blockages in the high-pressure circuit.	
The engine changes back to petrol.	The pressure is low.	The filter is clogged. Adjust the pressure.
	The gas pressure cannot be read.	Check the electrical connection and the efficiency of the pressure sensor.
	The gas injection lines are too high and longer than the period between two petrol injections.	Call a Landi Renzo Technician.

5.6 RETURNING TO IDLE

SYMPTOM	CAUSE	SOLUTION	
Stalling after slow return to idle.	The K coefficient has been increased in the high part of the map to obtain faster responses after flooring the accelerator pedal at high RPMs.	Connect the cells used during the return to idle better, reducing the value of the K coefficient in the first cells of the c.1200 to 1600 RPMs columns, or recalculate the carburation map (see NOTE at start of chapter).	
		Change the parameters in "Leaner carburation during return from cut-off" in F1 "Emissions" window.	
Stalling when returning from high RPMs.	The reduction unit becomes too cold while accelerating under torque, the gas increases in density and the carburation is thus too rich at idle.	Change the value from 2.5 ms to 2.0 ms. in the window F1-F7 injectors.	
		Check the hydraulic circuit.	
The engine is unable to establish rotation speed and the regime oscillates by several hundred RPMs.	The idle set well adjusted in values with and without air on.	Change the parameters in "Leaner carburation returning from cut-off" in F1 "Emissions" window.	
		Check the value assumed by the K coefficient during correct functioning at the idle, entering different accessory loads as necessary.	
		There are large discontinuities (10-20 K points) around the map zones that have been adjusted.	Connect the corresponding map zones better.
		The small tubes between the injector rail and the nozzles are too long and/or the nozzles are too far from the engine valves.	Review the position of the injector rail and decrease the length of the small tubes to bring the nozzle holes closer to the engine valves (if a hole cannot be made closer to the engine valves use 3 on nozzles).
	Check if this also happens when using petrol, in a less accentuated way.	Eliminate the defect when running on petrol.	

5.7 FULL OPEN THROTTLE ENGINE OPERATION

SYMPTOM	CAUSE	SOLUTION
The vehicle loses power because carburation is lean	The K coefficient of the cells in the power zone of the map is insufficient.	Increase the value of the K coefficient and make repeated acceleration tests with load (see NOTE at start of chapter).
	The injector nozzle diameter results in a total passage section that is insufficient to supply the engine in these conditions.	Check the nozzle diameter information on the car data sheet.
	The pressure variation reading is high, and remains below nominal value for a long time.	The reduction unit is damaged. The multivalve on the tank does not supply enough gas. Replace the gas filter.
The vehicle loses power because carburation is rich.	The K coefficient of the cells in the power zone of the map is too high.	Decrease the value of the K coefficient and make repeated acceleration tests with load (see NOTE at start of chapter).
After a certain period of functioning at full power the engine changes to petrol.	The reduction unit temperature falls to values that are too low, and as a result the OMEGAS control unit acquires the error in diagnosis.	The hydraulic circuit does not supply sufficient thermal power to maintain the reduction unit temperature while high rates of LPG are being supplied. Check the hydraulic circuit and the insulation.
	The gas injection time is longer than the engine revolution period.	The system changes back to gas when the injection time falls below the value set in "Max. injection time for change to gas" in the window F1 Vehicle configuration, F1 Change gas.
	The pressure falls more than 0.5 bars below the operating pressure.	Check the gas filter, check the gas in the tank, check for any "bottlenecks" in the high and low pressure piping.
	The signal detected by the Brown wire is too weak, and therefore the engine RPMs cannot be read at high regimes (note that the changeover switch cuts out and the engine has to be turned off and on again to return to gas).	Change how the Brown wire (antenna) is connected, or install a signal amplifier.
During sharp acceleration in low gears, the car jerks violently when the RPMs are high.	The engine over-RPM is triggered and the vehicle changes to petrol.	Drive at a lower RPMs regime.
	The Lambda sensor stops working and does not supply actual values.	Change the car to petrol and check that the sensor starts to work correctly again. If it doesn't, replace it.
Fuel consumptions differ considerably from the estimated average consumption for the type of vehicle.	Some zones of the map are too rich.	Correct the map zones, decreasing the values of the K coefficient in the cells involved (see NOTE at start of chapter).

5.8 FULL THROTTLE ACCELERATION AT MEDIUM-HIGH REGIMES

SYMPTOM	CAUSE	SOLUTION
Delay before acceleration starts after pressing the pedal.	The carburation map is not correct.	Recalibrate the vehicle.
	The high part of the main map presents discontinuities.	Connect the various zones of the main map better, maintaining control of the slowfast correctors (see NOTE at start of chapter) or recalibrate the carburation map F4.
	The distance between the injector coil and the points the gas is injected into the manifold is too great.	Review the installation, moving the coil injectors so as to reduce the length of the tubes and if necessary move the nozzles closer to the intake valves.
	The motor is not phased correctly to function with the alternative fuel.	Check that there is a suitable advance variator for the vehicle.
	The engine performs many extra injections and they are not replicated correctly when using gas (the red point that oscillates repeatedly between the actual injection time and 0 can be displayed in the map).	Contact Landi Renzo Technical Assistance.

5.9 HIGH TORQUE LOW RPM OPERATION

SYMPTOM	CAUSE	SOLUTION
At low regimes the vehicle sputters and jerks.	When moving this way the petrol control unit implements special strategies to manage ignition advances, with unfavourable effects on gas usage.	Check the programming of the OMEGAS control unit and proceed to recalibration the carburation map F4. If needed, check whether an advance variator can be installed.
	The advance variator changes the original advance too much.	Check that the programming of the advance variator is not too light, or is regulated so as to be off during the RPM regime in which the problem occurs.

5.10 MISCELLANEOUS

SYMPTOM	CAUSE	SOLUTION
The changeover switch does not light up.	The fuse on the red-black wire is burnt out.	Replace the fuse with one of the same type.
	The control unit is not programmed.	Program the control unit.
	Incorrect wiring installation. Petrol injectors excluded.	Fit suitable wiring.
	The OMEGAS control unit wiring connector is rusty.	Replace the connector or clean with suitable products.
	The changeover switch cable is damaged.	Repair or replace the cable.
	The changeover switch is not working.	Replace the changeover switch.
Long start up time.	Gas is mixing with the petrol.	Replace the Dmegas unit. An injector emulator has to be installed on some vehicle models. Contact Landi Renzo Technical Assistance.
The vehicle remains in motion with difficulty and stalls occasionally, and drivability is not good in any condition.	The OMEGAS control unit has been programmed with the wrong map file.	Check the file that is loaded and if incorrect reprogram the OMEGAS control unit.
	One (or more) injectors on the rail is (are) not functioning correctly.	Check the injector(s) and replace if necessary.
	The gas injector rail/injector exclusion cabling sequence has not been respected.	Check the system.
The engine functions uncertainly, particularly at idle, and gas can often be smelt.	There is a gas leak in some part of the system and correct calibration is therefore compromised.	Check the seals on the installation and the operating pressure of the reduction unit (see NOTE at start of chapter).
	The reduction unit valve seals have deteriorated, and this has changed their flow rates.	Check the operating pressure (see NOTE at start of chapter), and service or replace the reduction unit if necessary.
Carburation is rich at all regimes.	The seals of the 1 st and/or 2 nd stage lever valves are worn and the pressure reading is higher than the calibration value.	Check the operating pressure (see NOTE at start of chapter), and service or replace the reduction unit if necessary.
When under power with LPG there is an obvious and continuous consumption of petrol at the same time.	The injector emulator is defective and the vehicle is consuming LPG and petrol at the same time.	Replace the DMEGAS unit. An injector emulator has to be installed on some vehicle models. Contact Landi Renzo Technical Assistance.
After a few hundred kilometres of use with LPG the vehicle exhibits a clear worsening in emissions during use with petrol.	The carburation map is not optimized.	Modify the carburation map using a diagnostic leader (see NOTE at start of chapter).
Loss of water from the hydraulic circuit.	The bands are not attached correctly.	Review the installation.
The control unit has memorized errors in functioning diagnosis under the heading "Control Unit Self Diagnosis"	The control unit is not working.	Replace the control unit.
	There is no power permanently or sporadically in the Red/Black wire (+battery).	Check the connection to the battery, the continuity of the red/black wire, and the state of the fuse holder on the wire itself.
Control unit programming stops when "Load new Configuration F7" or "Control Unit Programming F8" is pressed.	The control unit is not communicating correctly.	Remove the supply fuse, replace within 4" and press the "Program" box. Check that the control unit has power, and that the interface cable is connected to the computer and the control unit.
	The control unit is currently programmed with an obsolete and non-compatible version of the firmware.	Program the control unit with a more up to date version.

5.11 DIAGNOSIS

The allow to see each components and system malfunctions, that can appear during the gas functioning.

In case of error, after you solve the trouble, it is possible to delete it using the appropriate button.

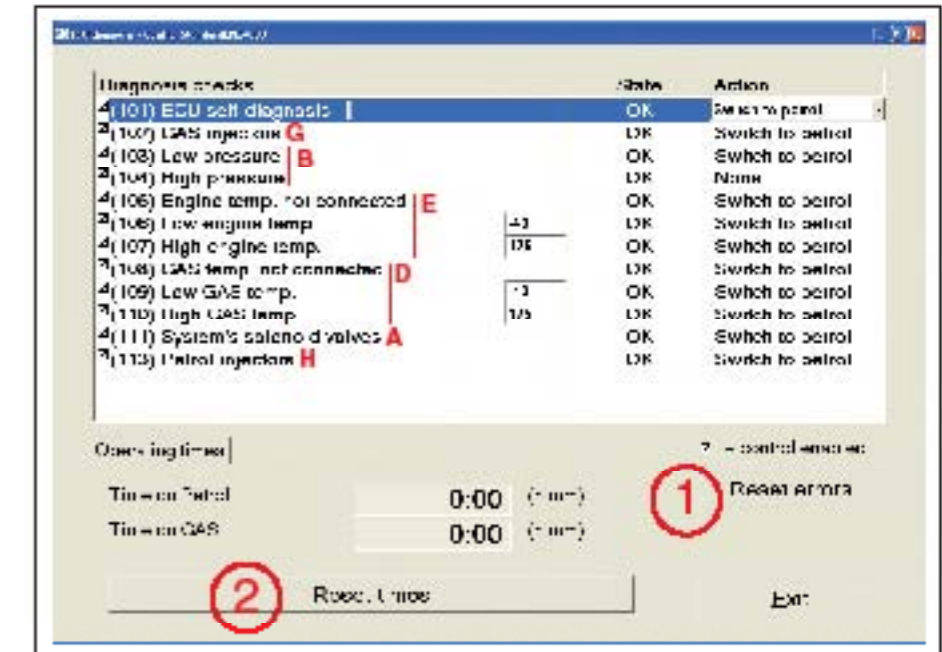

OMEGAS DIAGNOSIS PAGE

Fig. 27

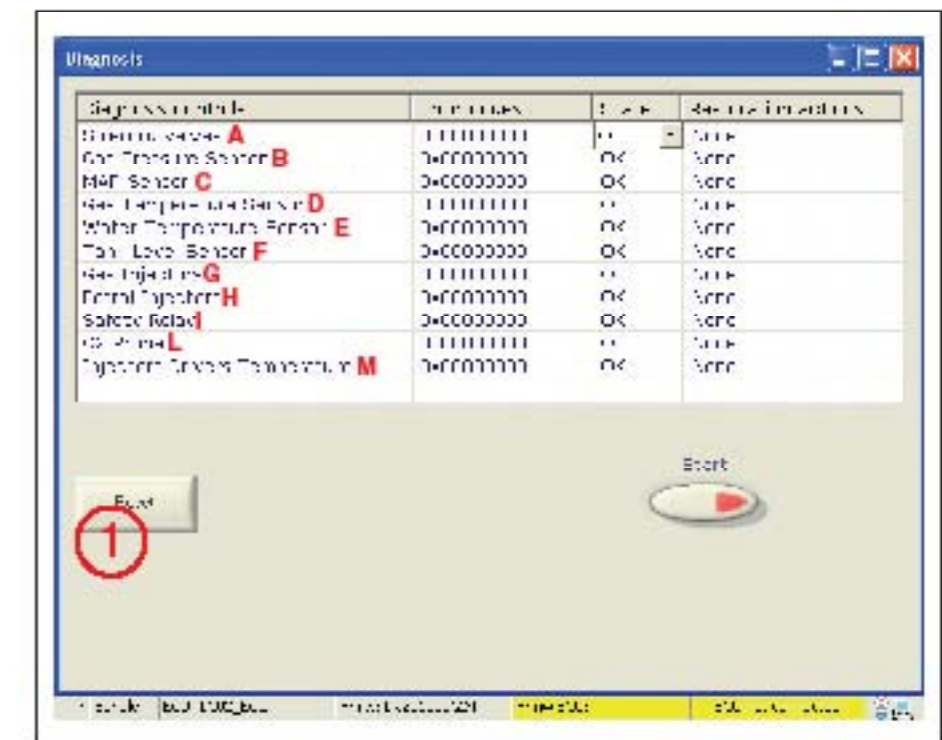

OMEGAS PLUS DIAGNOSIS PAGE

Fig. 28

The learnable malfunctions are:

A. SYSTEM SOLENOID VALVES DIAGNOSIS

It is possible to diagnose short circuits or open loops on the gas solenoid valves bobbins during the gas functioning. Remembering that in the wiring the two solenoid valves are connected in parallel, on the same connection it is necessary to enable the check of the pilot exit (pressure regulator solenoid valve check). The failure it is readed when for 5 seconds the current absorption measured is not inside the working range.

B. LOW PRESSURE DIAGNOSIS

During the gas functioning it is displayed an error if the readed pressure keeps for a certain time (low pressure time for the return, settable from the tool in the page Gas Level) in a level:

- lower than 0,4 bar for aspirated engine and 1 bar for turbo engine with lpg system
- lower than 1,54 bar for aspirated engine and 2,6 bar for turbo engine with cng system and at the same time the gas level is not reserve.

B. HIGH PRESSURE DIAGNOSIS

During the gas functioning it is displayed an error if the readed pressure keeps for a certain time (5 seconds) at a level:

- upper than 1,4 bar for aspirated engine and 2,85 bar for turbo engine with lpg system
- upper than 2,5 bar for aspirated engine and 4,1 bar for turbo engine with cng system

C. MAP SENSOR

An error will be displayed if the MAP sensor cable is connected and setted, the tool will diagnose:

- the cable is in short circuit versus ground or positive
- the cable is insulated
- the value displayed shows a pressure out of range

D. GAS TEMPERATURE DIAGNOSIS

It is possible to use this diagnosis only if from tool it has been setted the parameter "Enable change-over with gas temperature" in the Temperature page.

It is possible to learn during gas functioning:

- sensor not connected: in case of analogic consecutive learning for 10 seconds of a reference correspondent to absence of the temperature sensor
- too low temperature: for 10 seconds it is read a temperature lower than a value settable from the diagnosis page
- too high temperature: for 10 seconds it is read a temperature higher than a value settable from the diagnosis page

E. WATER TEMPERATURE DIAGNOSIS

It is possible to use this diagnosis only if from tool it has been setted the parameter "Enable change-over with water temperature" in the Temperature page.

It is possible to learn during gas functioning:

- sensor not connected: in case of analogic consecutive learning for 10 seconds of a reference correspondent to absence of the temperature sensor
- too low temperature: for 10 seconds it is read a temperature lower than a value settable from the diagnosis page
- too high temperature: for 10 seconds it is read a temperature higher than a value settable from the diagnosis page

F. GAS LEVEL SENSOR

An error will be displayed if the wiring of the level sensor is interrupted or in short circuit showing values out of range.

G. GAS INJECTORS DIAGNOSIS

During the gas functioning it is displayed an error for the correspondent injector in case it has learned successively for a certain number of injections (10) open loop cases or short circuit over the bobbin of the same injector.

H. PETROL INJECTORS DIAGNOSIS

In control unit it is done a check of the right connection of the injectors cutting harness.

In the gas functioning it is displayed the error for a certain time (8 seconds) are not learned any petrol injections on each channel of the injectors cutting harness. It is necessary that the vehicle it is not in cut-off and this check (to avoid strange conditions of petrol injections choking) it is done only if the revs are included between 650 and 1000 (minimum zone, where the petrol control unit does not acts its injectors with particularly strange strategy).

I. SAFETY RELAY DIAGNOSIS - ECU AUTOMATIC DIAGNOSIS

The tool displays an error in case of absence of subkey (therefore with relay not connected), it is learned downstream with a tension upper than 6V for a time upper than 150 seconds. This status correspond to the case of relay "sticked". It is also displayed an error of diagnosis when the revs downstream of the relay it is read a tension lower than 6V for 5 seconds.

Omegas Version

In the page it is displayed also a vehicle gas functioning and petrol functioning and hour counter; it is possible to reset

5.12 LR OMEGAS PROGRAM ERROR CODES

ERROR	CAUSE
PROGRAMMING	
P01	Cannot connect to control unit on COM or USB ports, cannot find a connected control unit. The control unit is not communicating or the communication pathway is not complete.
P02	The control unit connected is incompatible due to hardware or firmware.
P03	Error opening the programming file.
P04	Error in decryption of the programming file. (The reprogramming procedure requires the presence of Internet Explorer 5.5 or higher, with at least 128-bit cryptography).
P05	Incorrect programming voltage.
P06	Error in flash cancellation.
P07	Error during initialisation (BAD_PREPARATION).
P08	Error during initialisation (BAD_ERASE).
P09	Error in start programming phase.
P10	Null dimension in input data.
P11	Incorrect encryption mode.
P12	Generic programming error.
from P1000 up	Error in record programming (ERR.CODE-1000). Firmware writing was not successful, the programming must be repeated.
HARDWARE KEY	
H01	Error reading/writing hardware key.
H02	No hardware key compatible with the program is present.
H03	Key with expired data or number of accesses.
H04	Data not compatible with internal data of key.
CONNECTION	
C01	Cannot connect to control unit on COM or USB ports, cannot find a connected control unit. The control unit is not communicating or the communication pathway is not complete.
C02	Error loading control unit identification data.
C03	The firmware of the connected control unit is not compatible with the program installed on the PC.
C04	The program installed on the PC is not compatible with the control unit firmware.

CHAPTER 6 GLOSSARY

A

- Acceleration flat out from idle:** What happens when the driver starts with sudden pressure on the accelerator pedal (page 38).
- Acceleration slightly from idle:** What happens when the driver starts with gentle pressure on the accelerator pedal (page 38).

C

- Cylinder:** Part of the engine inside which combustion occurs, and where the piston slides (page 9).

E

- ECU:** Electronic Control Unit: The electronic unit that manages the engine injection system (page 18).
- Engine idling:** Functioning of the engine on while the vehicle is stopped, without the accelerator pedal being pressed (page 37).
- Engine RPM:** Number of engine revolutions per minute (page 18).
- Exhaust manifold:** Conduit to collect the burnt engine gases (page 9).

F

- Fast corrector:** Parameter of the fast adaptivity of the petrol (page 35).
- Filter unit:** Device to trap impurities present in the fuel (page 14).
- Firmware:** Control unit programme (page 43).
- Flash memory:** Microcontroller programme memory (page 18).
- Full open throttle engine operation:** Functioning of the engine at a high RPM and with a high load (above starting torque RPM and with the accelerator depressed) (page 41).

G

- Gas injectors:** Device that injects fuel gas into the intake manifold (page 5).
- Gas refuelling socket:** Device through which the gas bottle is refilled (page 9).
- Gas solenoid valve:** Device to cut off gas flow, controlled by the gas ECU (page 11).
- Gas tank:** Recipient of variable shape and size to contain specific gas as reserve (page 9).

H

Hardware key: Hardware protection device that allows particular software to be used (page 44).

I

Ignition advance: This is the number of degrees by which ignition of the fuel in the combustion chamber, when using alternative fuels their detonating power is slower than that of petrol (page 35).

Injector rail: Device to route the flow of fuel to the injectors (page 28).

Input signals: Signals incoming to the control unit needed for the operation of the programme (page 7).

Intake manifold: Conduit to collect and distribute fluids from the throttle body to the engine entrance (page 9).

K

K coefficient: This is the value read in the cells of the general map (F1 – F7 K entry) and is the ratio of the petrol injection time and the gas injection time, where the value "128" corresponds to the same injection time for the two fuels (page 37-38).

L

Lambda sensore: Sensor that measures the concentration of oxygen in the exhaust gases (page 35).

LPG multivalve: Device attached to the LPG bottle that performs the following functions:
 -Limitation and measurement of the level of LPG in the bottles;
 -Anti-explosion safety switch regulated by temperature and pressure;
 - Cut off of gas flow using an electromagnetic device;
 - Manual tap cutting off the flow (page 9).

LPG: Liquefied Petroleum Gas.

M

Manifold nozzle: Terminal conduit for gas flow (page 17).

Maximum current absorption: The maximum current absorbed by a component (page 18).

O

OBD: On Board Diagnosis. (page 35).

Output signals: Signals from the control unit needed for the system to operate (page 8).

P

Petrol injectors: Device that injects petrol into the intake manifold (page 5).

PLL processor speed: Operating frequency used by the microprocessor inside a computer to process data received (page 18).

Pressure reducer: Device to supply gas at a constant pressure less than its supply pressure (page 11).

R

Returning to idle: What happens when the accelerator pedal is released when the engine is at high RPM, and the engine speed falls to minimum (page 40).

RS 232 COM Port: Serial port for the PC-control unit interface (page 44).

S

Slow corrector: Parameter of the slow adaptivity (flow) of the petrol (page 35).

Switch petrol/gas: Device that allows the user to change the vehicle fuel from petrol to gas and vice versa (page 20).

U

USB 1.1/2.0 Port: Serial port for the PC-control unit interface (page 44).

W

Water temperature sensor: Device used to measure the temperature values needed for the gas to flow (page 13).

Wiring harness: Assembly of wires that connect the parts of the equipment and electrical or electronic systems (page 9).

190336440/2
Components and installation handbook LR OMEGAS/GI 5/6/8 cil.
update 07/2010



via Nobel, 2 | 42025 Corte Tegge | Cavriago (RE) | Italia
Tel. +39 0522 9433 | Fax +39 0522 944044 | www.landi.it | e-mail: info@landi.it